



QUAKER
COMMERCIAL WINDOWS AND DOORS



**E200 Series
HC60
2 3/8" Frame Depth
Picture Window (Fixed)**

E200 SERIES PICTURE WINDOW (FIXED)

The Quaker Emerge E200 Series Picture window is ideal for a variety of applications including - Energy Efficient, Institutions, Education, Apartments and Assisted Living.

FEATURES

- ◇ **Commercial Framing System**
 - 2 3/8" main frame
 - Frame and sill mortised and joined with screw fasteners
- ◇ **Enhanced Design**
 - Azon pour and debridge thermal break is 1/2" wide in all main frame and vent rail extrusions
- ◇ **Glazing**
 - 1" insulated glass

BENEFITS

- ◇ The capacity to match exterior colors for unique project facades
- ◇ The ability to facilitate large sizes for taller and wider window openings

OPTIONS

- ◇ **Available Configurations**
 - Picture window
 - Geometric shapes
- ◇ **Muntin Choices**
 - Internal or simulated divided lites available
- ◇ **Nailing Fin**
- ◇ **Glazing**
 - Capillary tubes
 - Argon gas
 - Wide variety of glazing, tinting and thickness options
- ◇ **Panning & Trim Choices**
 - Wide variety of panning, receptor and trim available
- ◇ **Mulling**
 - Wide variety of structural mulls

PERFORMANCE

- ◇ Structural & Thermal (test reports or thermal simulations available upon request)

Model	Picture Window (Fixed)
AAMA/WDMA/CSA 101/IS.2/A440-08 Rating	HC60
Structural Load P.S.F.	90
Air at 50 MPH (cfm/ft ²)	0.01
Water (No Penetration) P.S.F.	7.52
U-Value (with Low-E and Argon)	0.27-0.32
SHGC (with Low-E and Argon)	0.16-0.37

Window test size: 64" x 71"



Our products are tested to the standards of and certified by the American Architectural Manufacturer's Association, the National Fenestration Rating Council and the Window & Door Manufacturers Association.



QUAKER
COMMERCIAL WINDOWS AND DOORS

ARCHITECTURAL PAINT COATINGS AND FINISHES

◇ Baked on powder coat finish meets ANSA/AAMA 2604 specs and is available in unlimited colors

- 11 Popular Colors

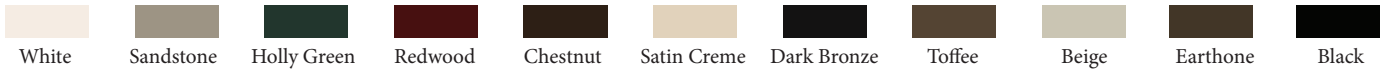

- 19 Impressive Colors

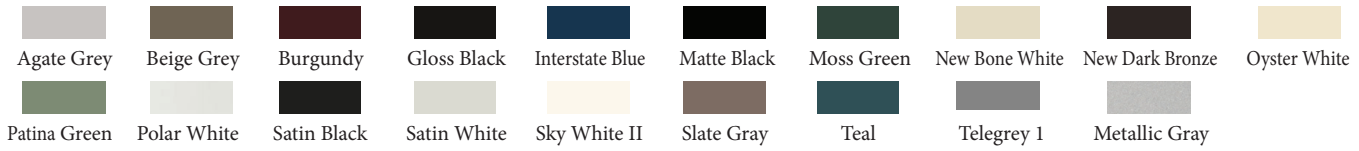

- 7 Resemble Colors (painted finish resembling anodized)



- Unlimited Custom Colors

* Printed colors shown here may not accurately depict actual painted colors. Color samples are available upon request.

◇ ANSA/AAMA 2605 powder coat finishes

◇ AAMA 611-98 Class I clear and tinted anodized finishes

Our products are tested to the standards of and certified by the American Architectural Manufacturer's Association, the National Fenestration Rating Council and the Window & Door Manufacturers Association.



QUAKER
COMMERCIAL WINDOWS AND DOORS



QUAKER
COMMERCIAL WINDOWS AND DOORS



**E200 Series
HC60
2 3/8" Frame Depth
Picture Window (Fixed)**

E200 PW WITH NAILING FIN

This document contains confidential and proprietary information intended for the private use of Quaker.
© 2016 Quaker Window Products Co., INC. All rights reserved.
Quaker reserves the right to change any/all designs without notice. Due to periodic re-certification requirements, result shown may vary.

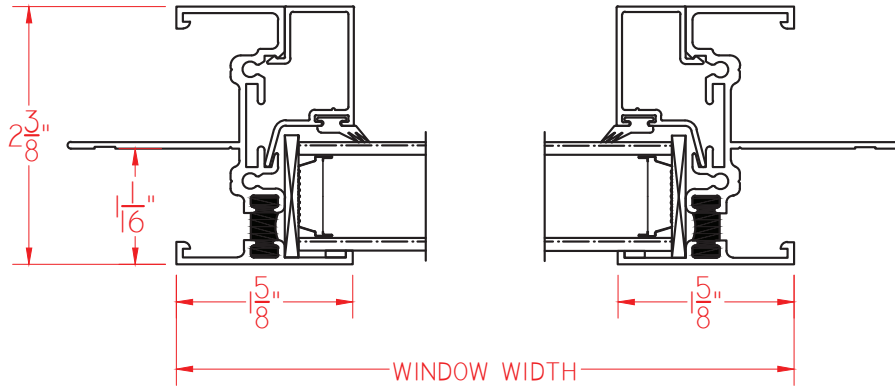

① HORIZONTAL CROSS SECTION

Ⓐ VERTICAL CROSS SECTION

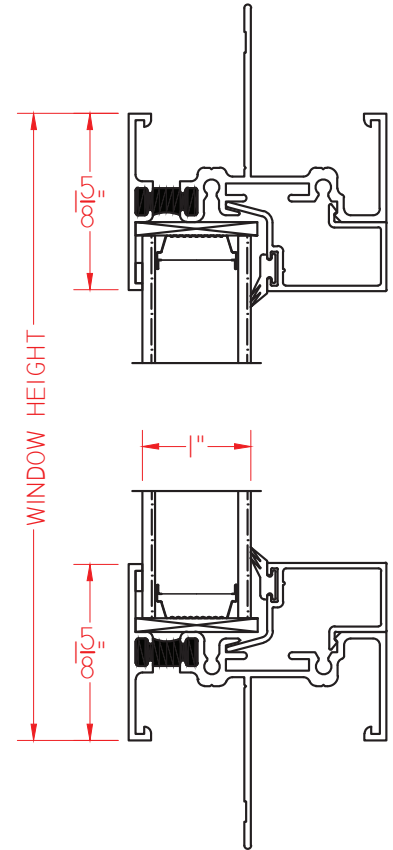
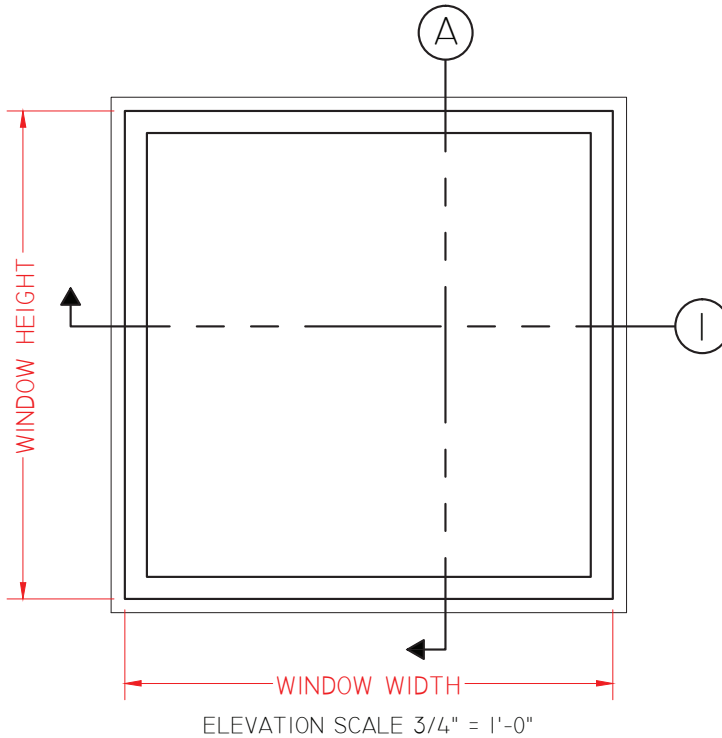

02.04.2015 VERSION 1.0

SCALE 1:2

Our products are tested to the standards of and certified by the American Architectural Manufacturer's Association, the National Fenestration Rating Council and the Window & Door Manufacturers Association.



QUAKER
COMMERCIAL WINDOWS AND DOORS



QUAKER
COMMERCIAL WINDOWS AND DOORS



**E200 Series
HC60
2 3/8" Frame Depth
Picture Window (Fixed)**

E200 PW WITHOUT NAILING FIN

This document contains confidential and proprietary information intended for the private use of Quaker.
© 2016 Quaker Window Products Co., INC. All rights reserved.
Quaker reserves the right to change any/all designs without notice. Due to periodic re-certification requirements, result shown may vary.

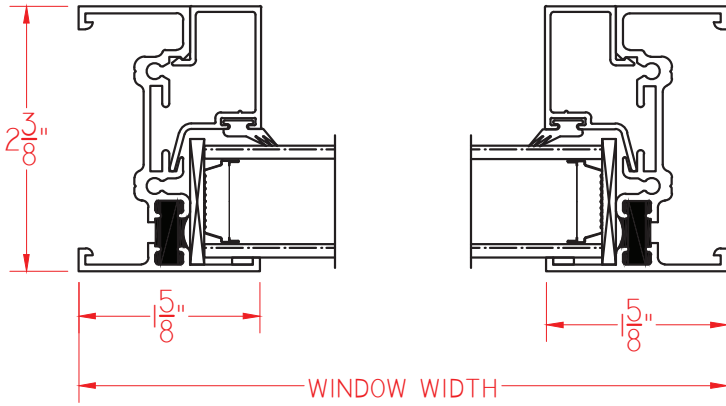

① HORIZONTAL CROSS SECTION

Ⓐ VERTICAL CROSS SECTION

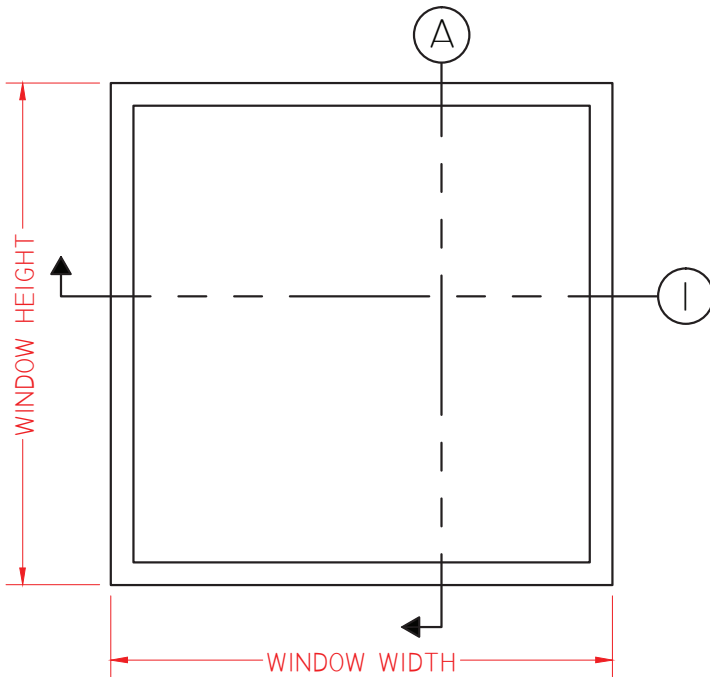

ELEVATION SCALE 3/4" = 1'-0"

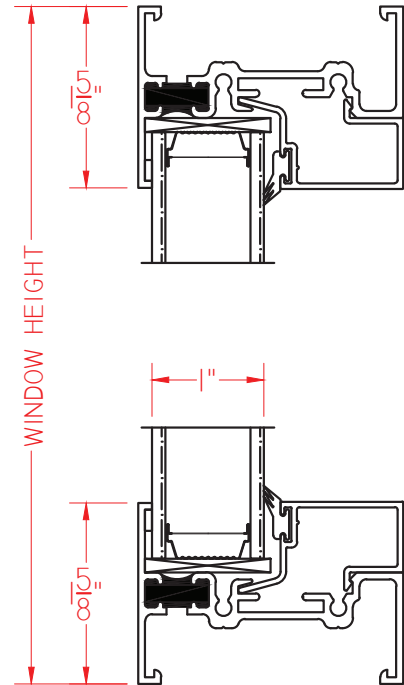

02.04.2015 VERSION 1.0

SCALE 1:2

Our products are tested to the standards of and certified by the American Architectural Manufacturer's Association, the National Fenestration Rating Council and the Window & Door Manufacturers Association.



QUAKER
COMMERCIAL WINDOWS AND DOORS



QUAKER
COMMERCIAL WINDOWS AND DOORS



**E200 Series
HC60
2 3/8" Frame Depth
Picture Window (Fixed)**

E200 PW WITH CE-13287 DOUBLE JAMB (V)

This document contains confidential and proprietary information intended for the private use of Quaker.
© 2016 Quaker Window Products Co., INC. All rights reserved.
Quaker reserves the right to change any/all designs without notice. Due to periodic re-certification requirements, result shown may vary.

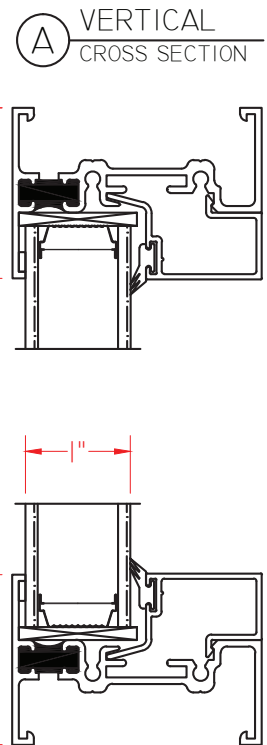
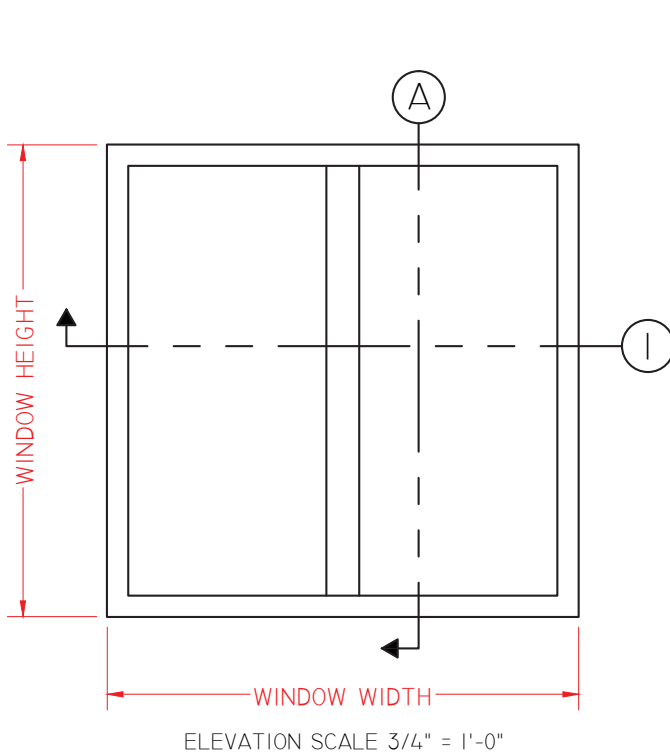
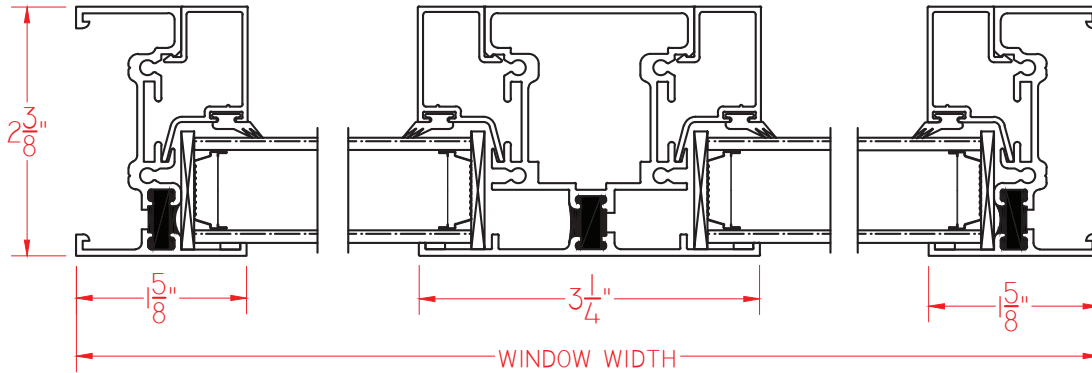

02.23.2015 VERSION 1.0

SCALE 1:2

Our products are tested to the standards of and certified by the American Architectural Manufacturer's Association, the National Fenestration Rating Council and the Window & Door Manufacturers Association.



QUAKER
COMMERCIAL WINDOWS AND DOORS



QUAKER
COMMERCIAL WINDOWS AND DOORS



**E200 Series
HC60
2 3/8" Frame Depth
Picture Window (Fixed)**

E200 PW WITH CE-13287 DOUBLE JAMB (H)

This document contains confidential and proprietary information intended for the private use of Quaker.
© 2016 Quaker Window Products Co., INC. All rights reserved.
Quaker reserves the right to change any/all designs without notice. Due to periodic re-certification requirements, result shown may vary.

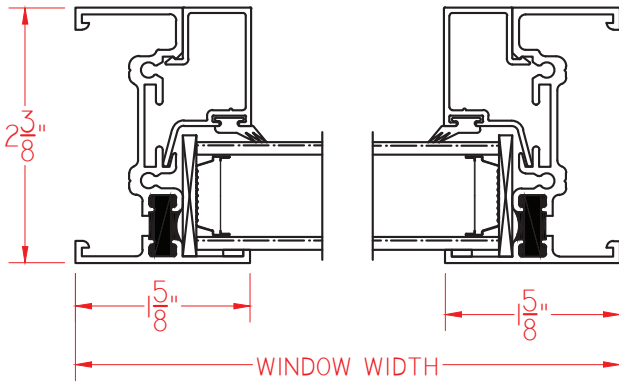

A VERTICAL CROSS SECTION

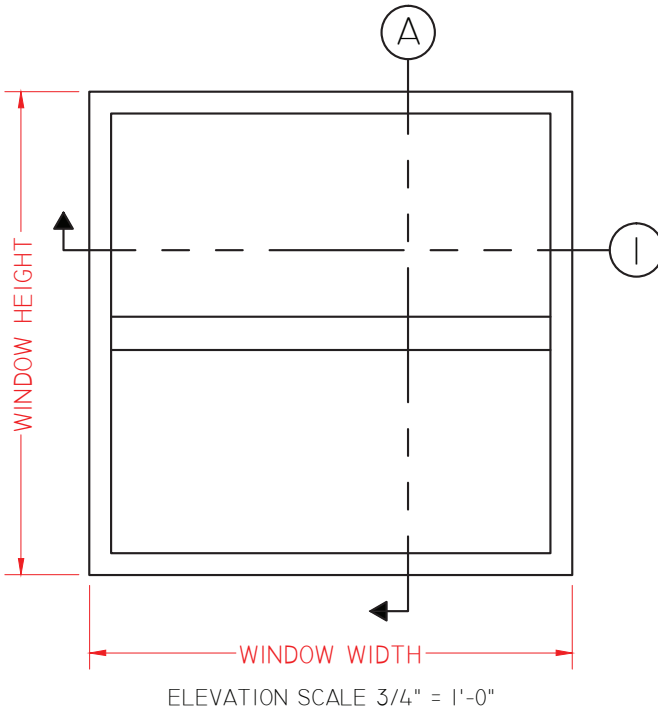
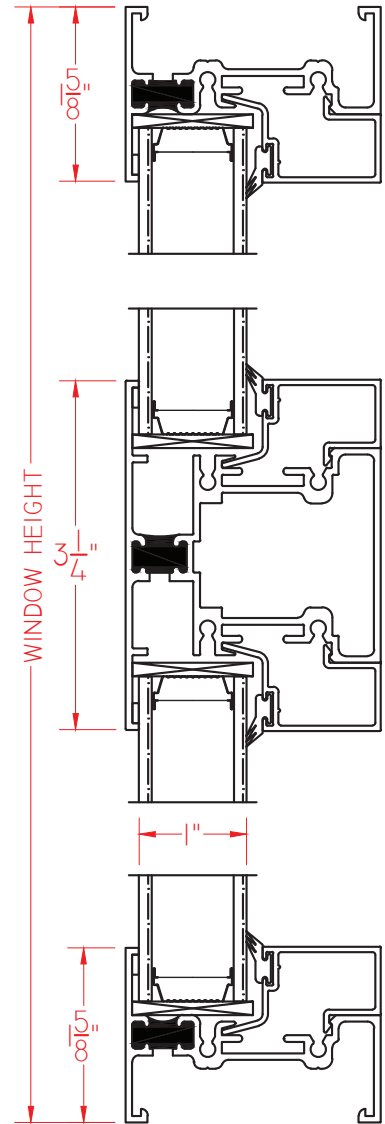

02.23.2015 VERSION 1.0

SCALE 1:2

Our products are tested to the standards of and certified by the American Architectural Manufacturer's Association, the National Fenestration Rating Council and the Window & Door Manufacturers Association.



QUAKER
COMMERCIAL WINDOWS AND DOORS



QUAKER
COMMERCIAL WINDOWS AND DOORS



**E200 Series
HC60
2 3/8" Frame Depth
Picture Window (Fixed)**

E200 PW WITH MW-23312 DOUBLE JAMB (V)

This document contains confidential and proprietary information intended for the private use of Quaker.
© 2016 Quaker Window Products Co., INC. All rights reserved.
Quaker reserves the right to change any/all designs without notice. Due to periodic re-certification requirements, result shown may vary.

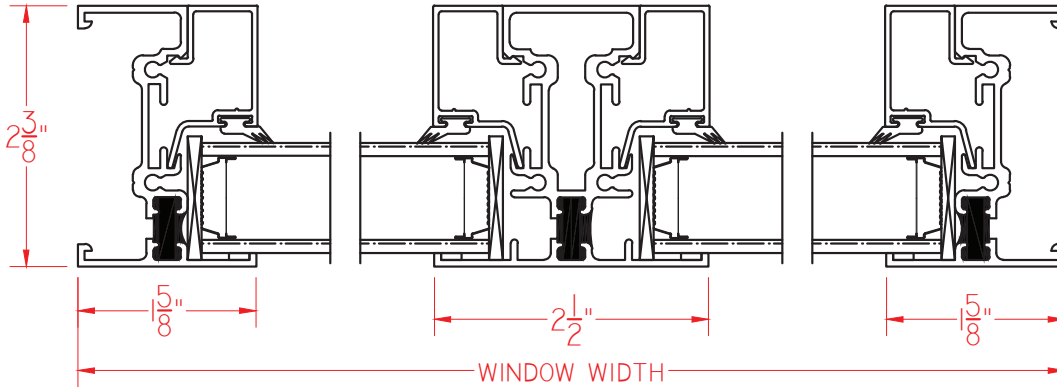

① HORIZONTAL CROSS SECTION

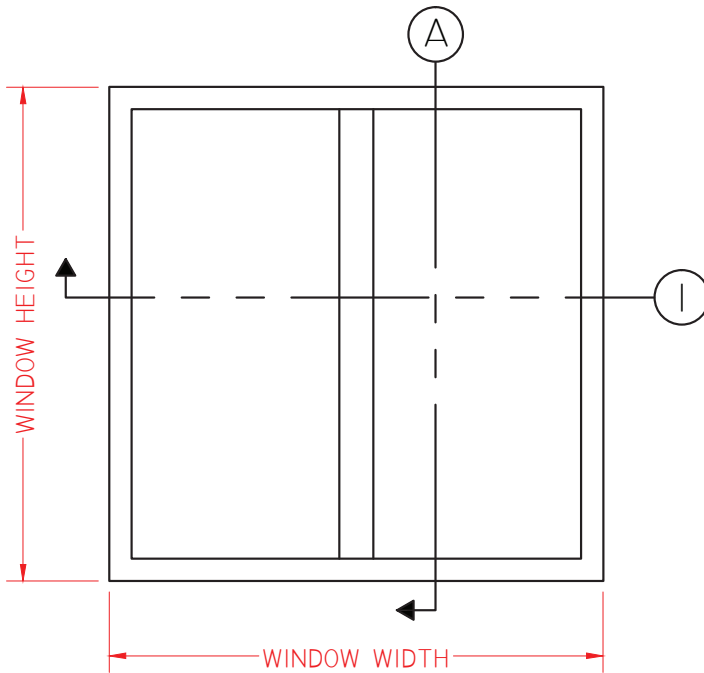

ELEVATION SCALE 3/4" = 1'-0"

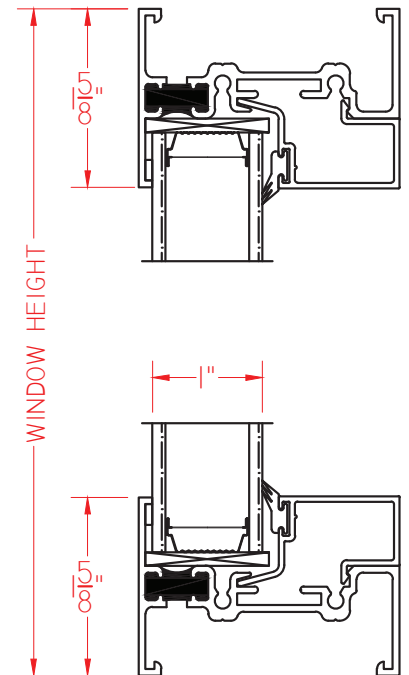

Ⓐ VERTICAL CROSS SECTION

02.23.2015 VERSION 1.0

SCALE 1:2

Our products are tested to the standards of and certified by the American Architectural Manufacturer's Association, the National Fenestration Rating Council and the Window & Door Manufacturers Association.



QUAKER
COMMERCIAL WINDOWS AND DOORS



QUAKER
COMMERCIAL WINDOWS AND DOORS



**E200 Series
HC60
2 3/8" Frame Depth
Picture Window (Fixed)**

E200 PW WITH MW-23312 DOUBLE JAMB (H)

This document contains confidential and proprietary information intended for the private use of Quaker.
© 2016 Quaker Window Products Co., INC. All rights reserved.
Quaker reserves the right to change any/all designs without notice. Due to periodic re-certification requirements, result shown may vary.

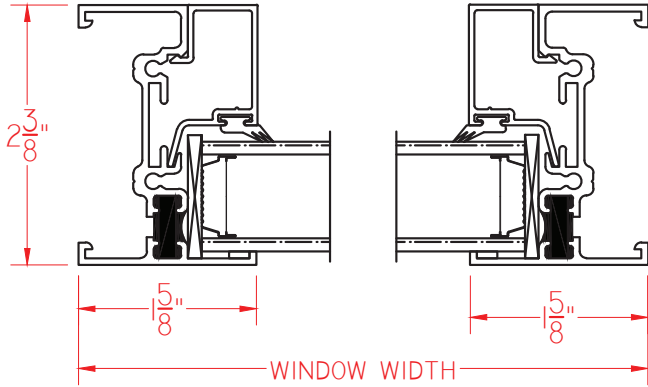

① HORIZONTAL CROSS SECTION

Ⓐ VERTICAL CROSS SECTION

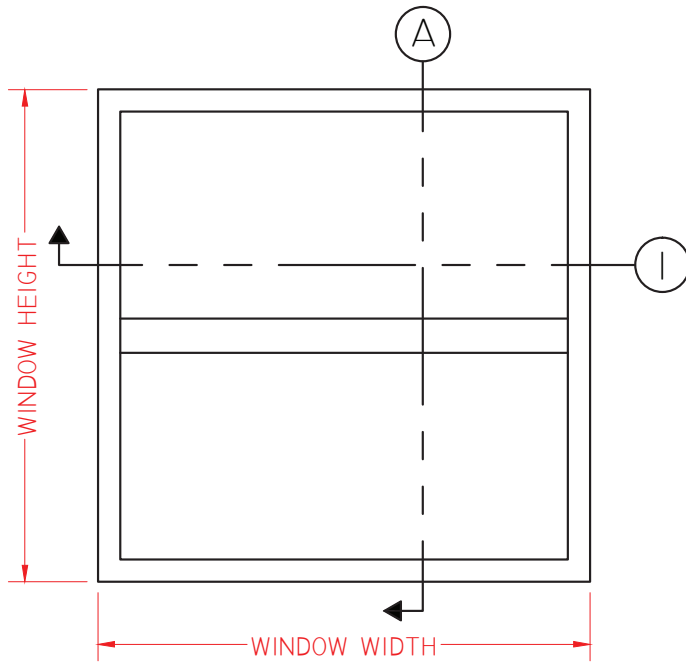
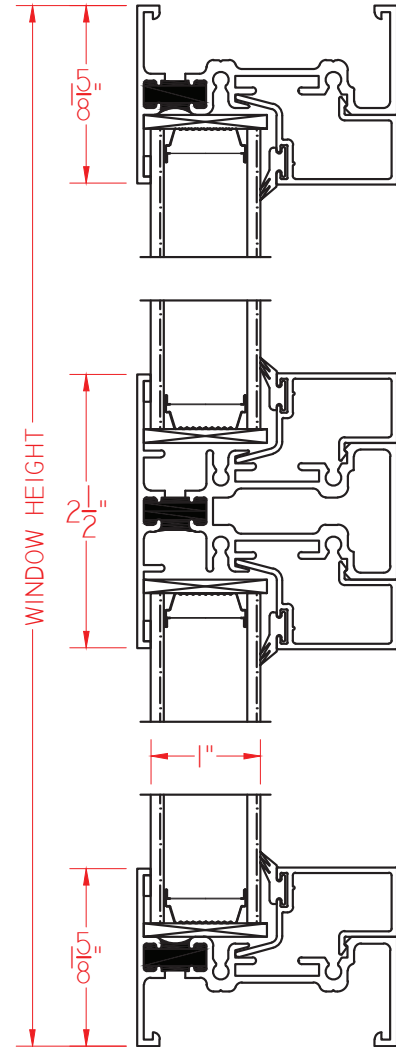

ELEVATION SCALE 3/4" = 1'-0"

02.23.2015 VERSION 1.0

SCALE 1:2

Our products are tested to the standards of and certified by the American Architectural Manufacturer's Association, the National Fenestration Rating Council and the Window & Door Manufacturers Association.



QUAKER
COMMERCIAL WINDOWS AND DOORS