

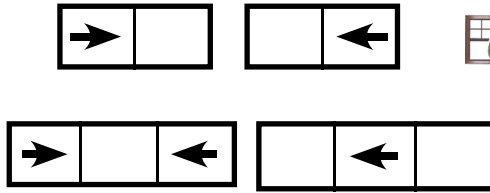

**QUAKER**  
COMMERCIAL WINDOWS AND DOORS



**emerge** **E350 Series**  
**CW-PG50**  
**3 1/4" Frame Depth**  
**Horizontal Slider**

## E350 SERIES HORIZONTAL SLIDER

The Quaker Emerge E350 Series Horizontal Slider window is ideal for a variety of applications including - Energy Efficient, Institutions, Education, Apartments and Assisted Living.

### FEATURES

- ◇ **Commercial Framing System**
  - 3 1/4" main frame
  - 0.062" wall thickness of frame
- ◇ **Thermally Enhanced Design**
  - Azon pour and debridge thermal break is 1/2" wide in all main frame and vent rail extrusions
  - Frame and sash mitered and joined with screw fasteners
  - Fin seal wool pile weatherstripping
  - Positive interlocks
- ◇ **Glazing**
  - 1" insulated glass
- ◇ **Hardware**
  - Brass rollers with stainless steel axle pins for easy operation
  - Gravity latch
- ◇ **Screen**
  - Extruded aluminum screen frame with BetterVue™ mesh

### BENEFITS

- ◇ The capacity to match exterior colors for unique project facades
- ◇ The ability to facilitate large sizes for taller and wider window openings

### PERFORMANCE

- ◇ Structural & Thermal (test reports or thermal simulations available upon request)

Model	Horizontal Slider
AAMA/WDMA/CSA 101/I.S.2/A440-08 Rating	CW-PG50
Structural Load P.S.F.	75.19
Air at 50 MPH (cfm/ft <sup>2</sup> )	0.08
Water (No Penetration) P.S.F.	10.03
U-Value (with Low-E and Argon)	0.36 - 0.41
SHGC (with Low-E and Argon)	0.13 - 0.31

Window test size: 72" x 60"

Operating Force: 8 lbf (maintain motion), 10 lbf (latches)

### OPTIONS

- ◇ **Available Configurations**
  - Fixed-Active
  - Active-Fixed
  - Active-Fixed-Active
  - Fixed-Active-Fixed
- ◇ **Muntin Choices**
  - Internal or simulated divided lites available
- ◇ **Hardware**
  - Sweep lock
  - Night latch
  - Limited travel latch
  - Wide variety of locking and operating hardware options
- ◇ **Nailing Fin**
- ◇ **Screen**
  - Extruded aluminum screen frame with aluminum wire mesh
  - Extruded aluminum screen frame with sunscreen mesh
  - Extruded aluminum screen frame with stainless steel 0.009" thickness mesh
- ◇ **Glazing**
  - Capillary tubes
  - Argon gas
  - Wide variety of glazing, tinting and thickness options
- ◇ **Panning & Trim Choices**
  - Wide variety of panning, receptor and trim available
- ◇ **Mulling**
  - Wide variety of structural mulls
- ◇ **Specialty**
  - Attached exterior or interior storm window
  - Extension jambs

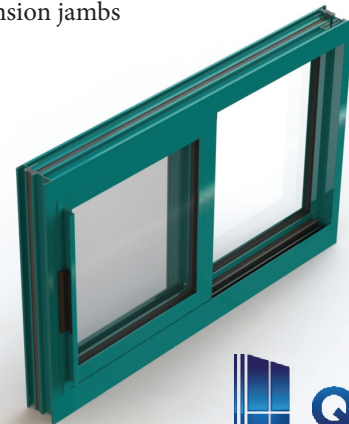

Our products are tested to the standards of and certified by the American Architectural Manufacturer's Association, the National Fenestration Rating Council and the Window & Door Manufacturers Association.



**QUAKER**  
COMMERCIAL WINDOWS AND DOORS

# ARCHITECTURAL PAINT COATINGS AND FINISHES

◇ Baked on powder coat finish meets ANSA/AAMA 2604 specs and is available in unlimited colors

- 11 Popular Colors

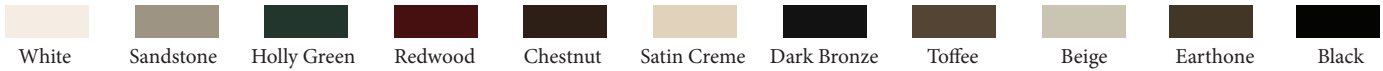

- 19 Impressive Colors

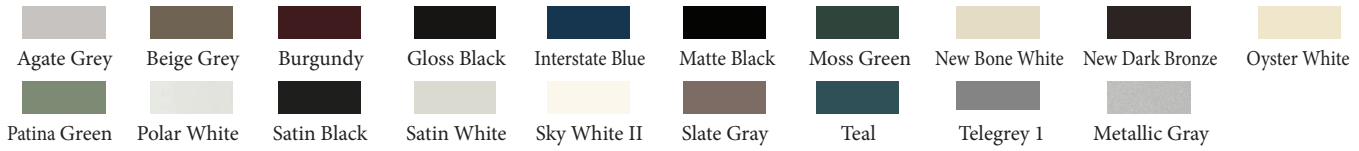

- 7 Resemble Colors (painted finish resembling anodized)



- Unlimited Custom Colors

\* Printed colors shown here may not accurately depict actual painted colors. Color samples are available upon request.

◇ ANSA/AAMA 2605 powder coat finishes

◇ AAMA 611-98 Class I clear and tinted anodized finishes

Our products are tested to the standards of and certified by the American Architectural Manufacturer's Association, the National Fenestration Rating Council and the Window & Door Manufacturers Association.



**QUAKER**  
COMMERCIAL WINDOWS AND DOORS



**QUAKER**  
COMMERCIAL WINDOWS AND DOORS



**emerge** **E350 Series**  
**CW-PG50**  
**3 1/4" Frame Depth**  
**Horizontal Slider**

# E350 SL WITH NAILING FIN

This document contains confidential and proprietary information intended for the private use of Quaker.  
© 2016 Quaker Window Products Co., INC. All rights reserved.  
Quaker reserves the right to change any/all designs without notice. Due to periodic re-certification requirements, result shown may vary.

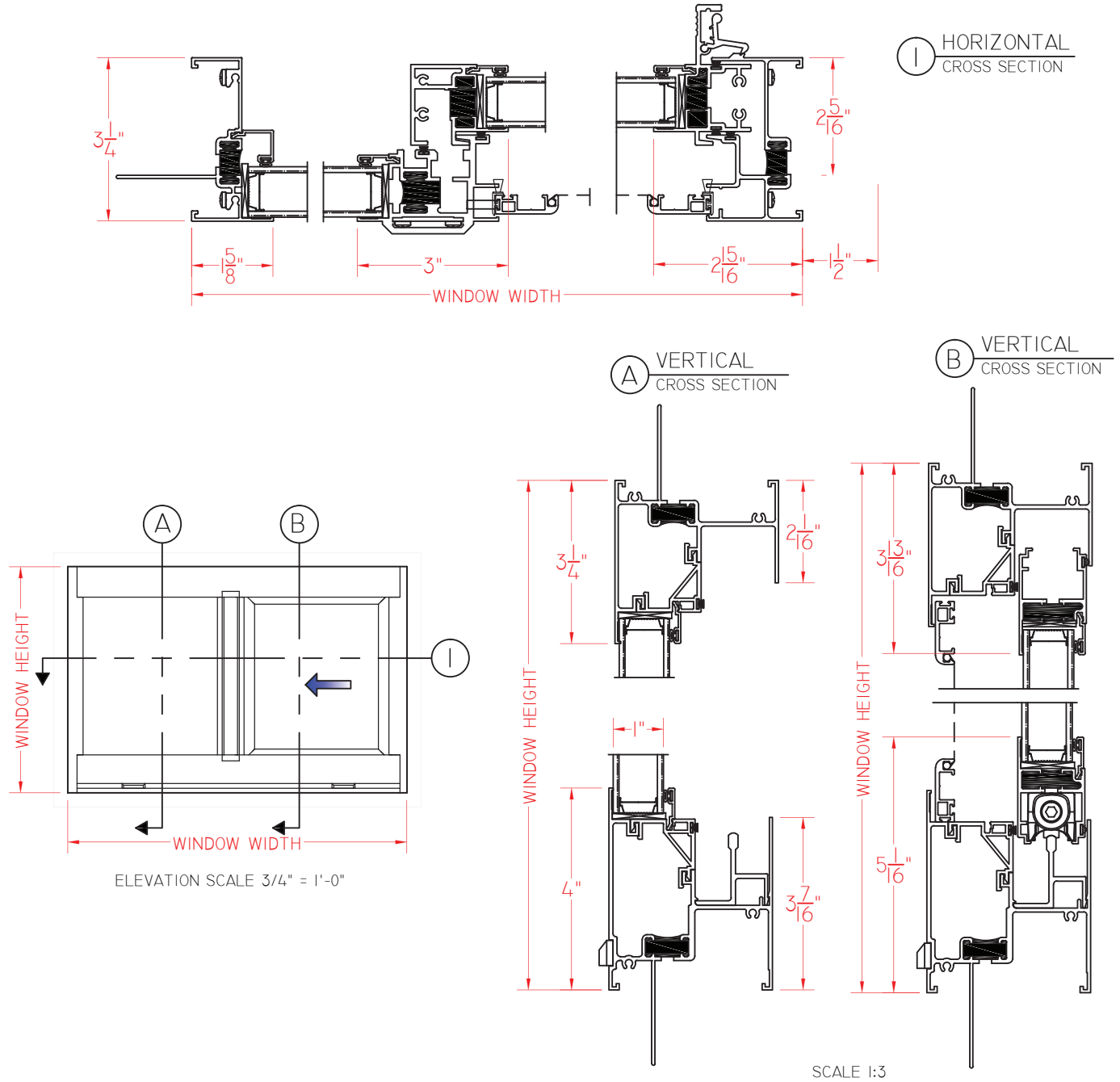

Our products are tested to the standards of and certified by the American Architectural Manufacturer's Association, the National Fenestration Rating Council and the Window & Door Manufacturers Association.



**QUAKER**  
COMMERCIAL WINDOWS AND DOORS



**QUAKER**  
COMMERCIAL WINDOWS AND DOORS

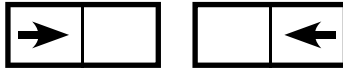

**emerge** **E350 Series**  
**CW-PG50**  
**3 1/4" Frame Depth**  
**Horizontal Slider**

# E350 SL WITHOUT NAILING FIN

This document contains confidential and proprietary information intended for the private use of Quaker.  
© 2016 Quaker Window Products Co., INC. All rights reserved.  
Quaker reserves the right to change any/all designs without notice. Due to periodic re-certification requirements, result shown may vary.

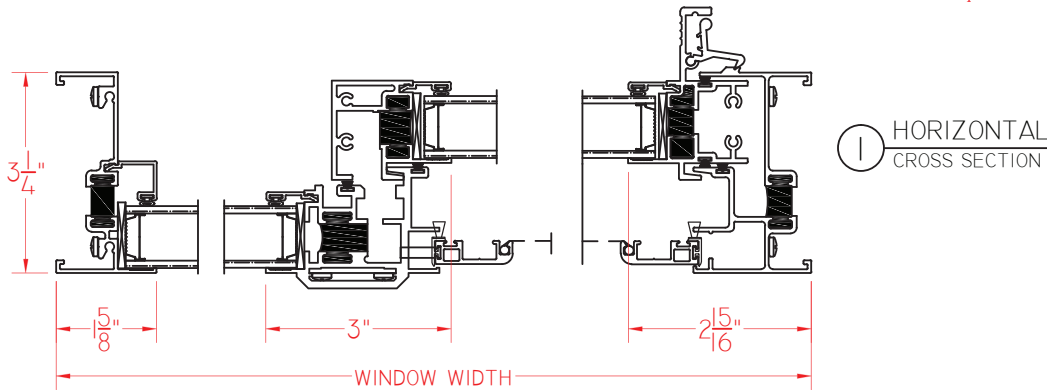

**① A VERTICAL CROSS SECTION**

**① B VERTICAL CROSS SECTION**

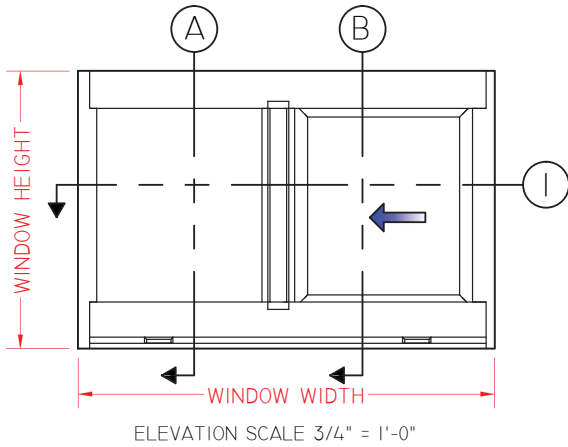
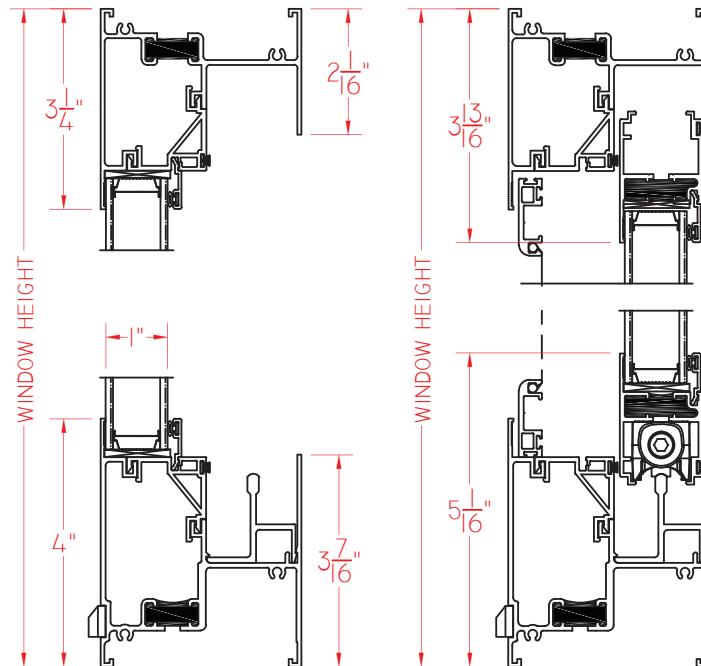

SCALE 1:3

Our products are tested to the standards of and certified by the American Architectural Manufacturer's Association, the National Fenestration Rating Council and the Window & Door Manufacturers Association.



**QUAKER**  
COMMERCIAL WINDOWS AND DOORS



**QUAKER**  
COMMERCIAL WINDOWS AND DOORS

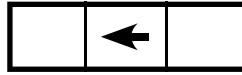

**emerge** **E350 Series**  
**CW-PG50**  
**3 1/4" Frame Depth**  
**Horizontal Slider**

# E350 CENTER VENT SLIDER WITH NAILING FIN

This document contains confidential and proprietary information intended for the private use of Quaker.  
© 2016 Quaker Window Products Co., INC. All rights reserved.  
Quaker reserves the right to change any/all designs without notice. Due to periodic re-certification requirements, result shown may vary.

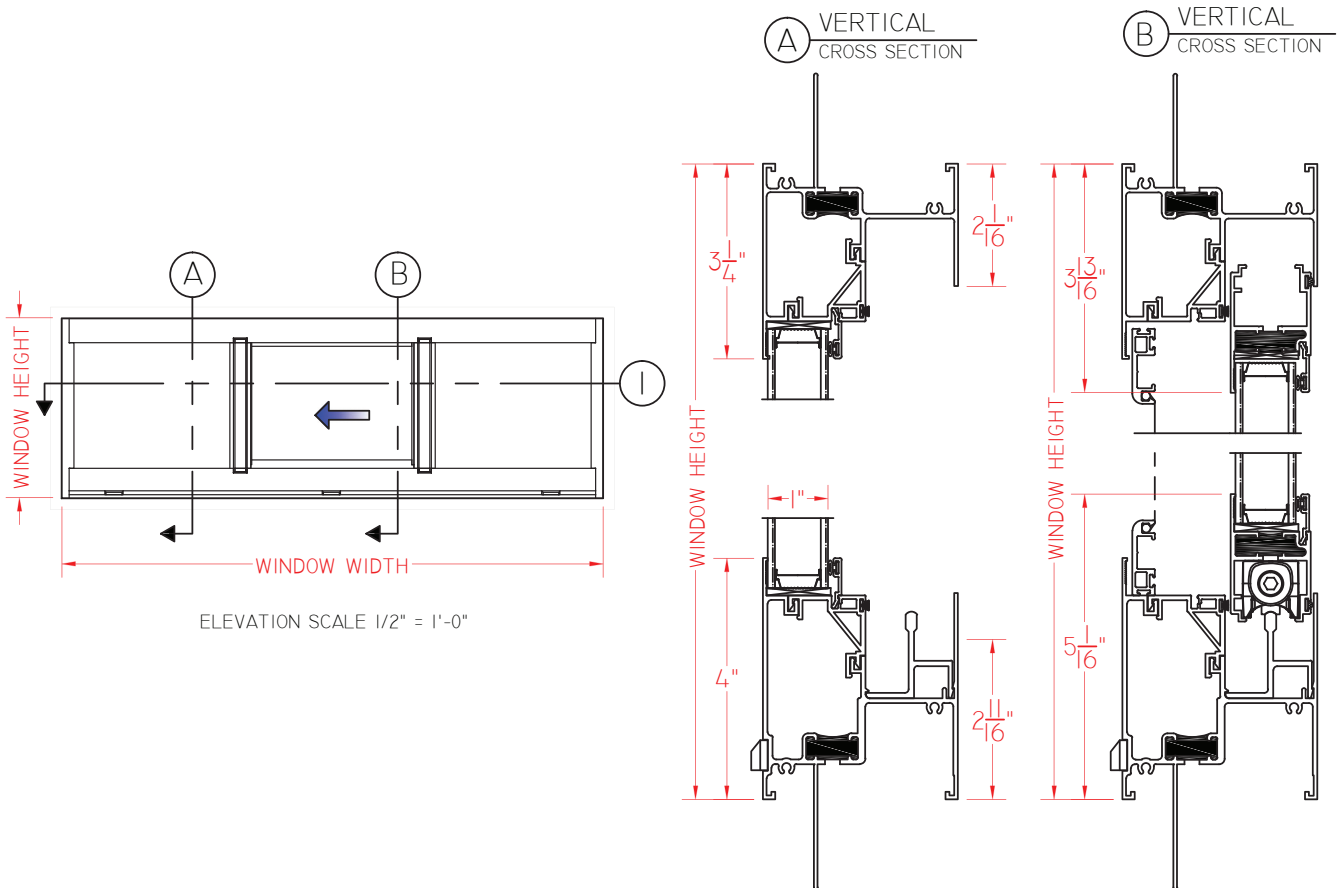
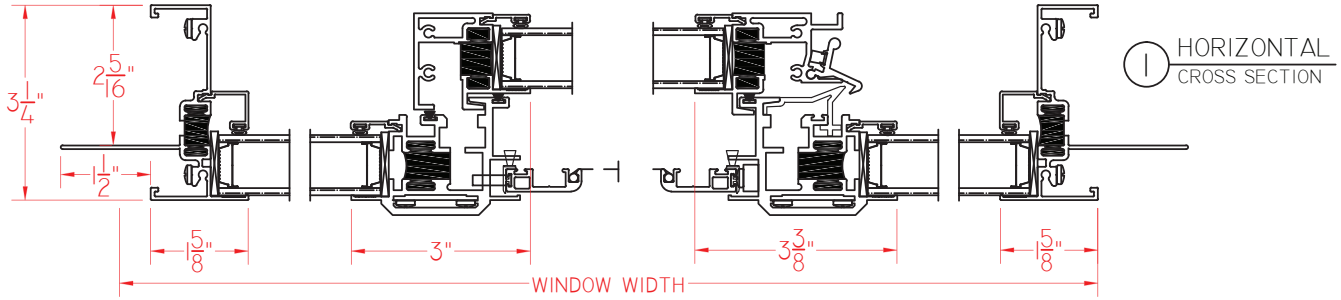

Our products are tested to the standards of and certified by the American Architectural Manufacturer's Association, the National Fenestration Rating Council and the Window & Door Manufacturers Association.



**QUAKER**  
COMMERCIAL WINDOWS AND DOORS



**QUAKER**  
COMMERCIAL WINDOWS AND DOORS

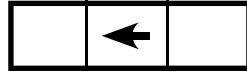

**emerge** **E350 Series**  
**CW-PG50**  
**3 1/4" Frame Depth**  
**Horizontal Slider**

# E350 CENTER VENT SLIDER WITHOUT NAILING FIN

This document contains confidential and proprietary information intended for the private use of Quaker.  
© 2016 Quaker Window Products Co., INC. All rights reserved.  
Quaker reserves the right to change any/all designs without notice. Due to periodic re-certification requirements, result shown may vary.

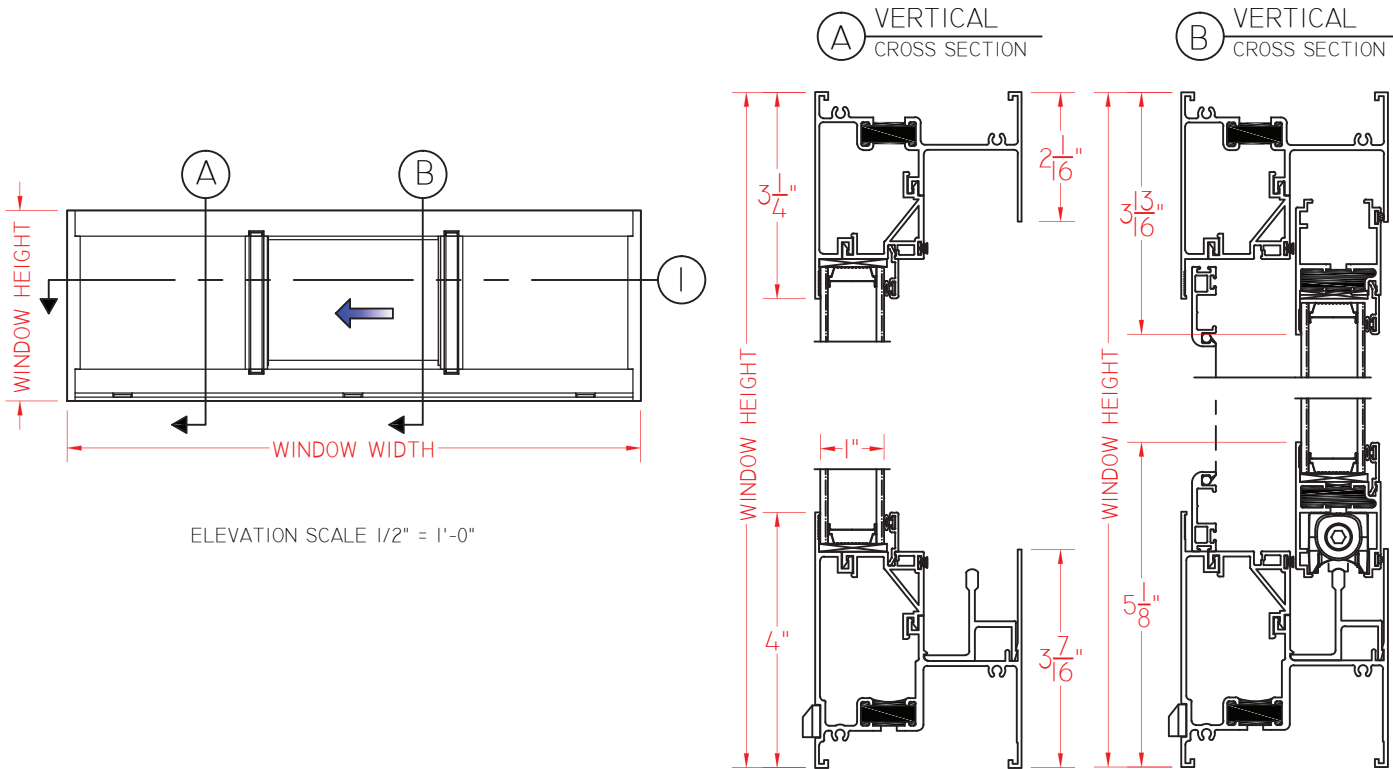
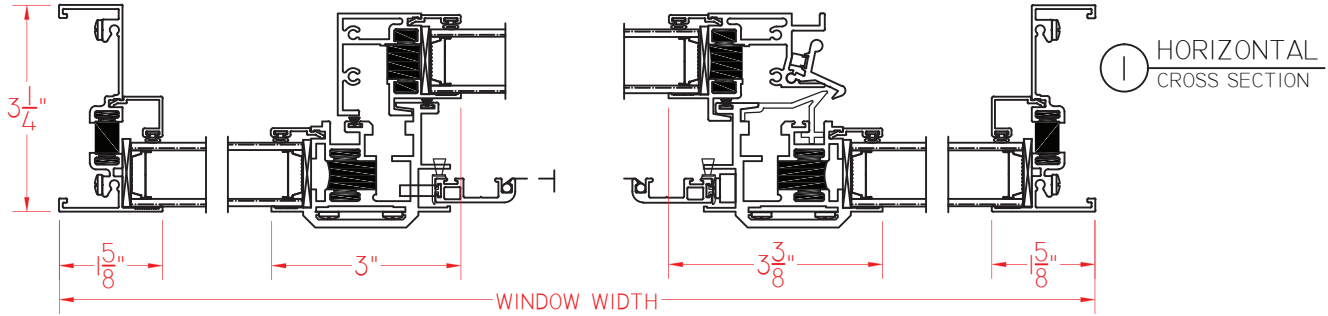

SCALE 1:3

Our products are tested to the standards of and certified by the American Architectural Manufacturer's Association, the National Fenestration Rating Council and the Window & Door Manufacturers Association.



**QUAKER**  
COMMERCIAL WINDOWS AND DOORS



**QUAKER**  
COMMERCIAL WINDOWS AND DOORS



**emerge** **E350 Series**  
**CW-PG50**  
**3 1/4" Frame Depth**  
**Horizontal Slider**

# E350 END VENT SLIDER WITH NAILING FIN

This document contains confidential and proprietary information intended for the private use of Quaker.  
© 2016 Quaker Window Products Co., INC. All rights reserved.  
Quaker reserves the right to change any/all designs without notice. Due to periodic re-certification requirements, result shown may vary.

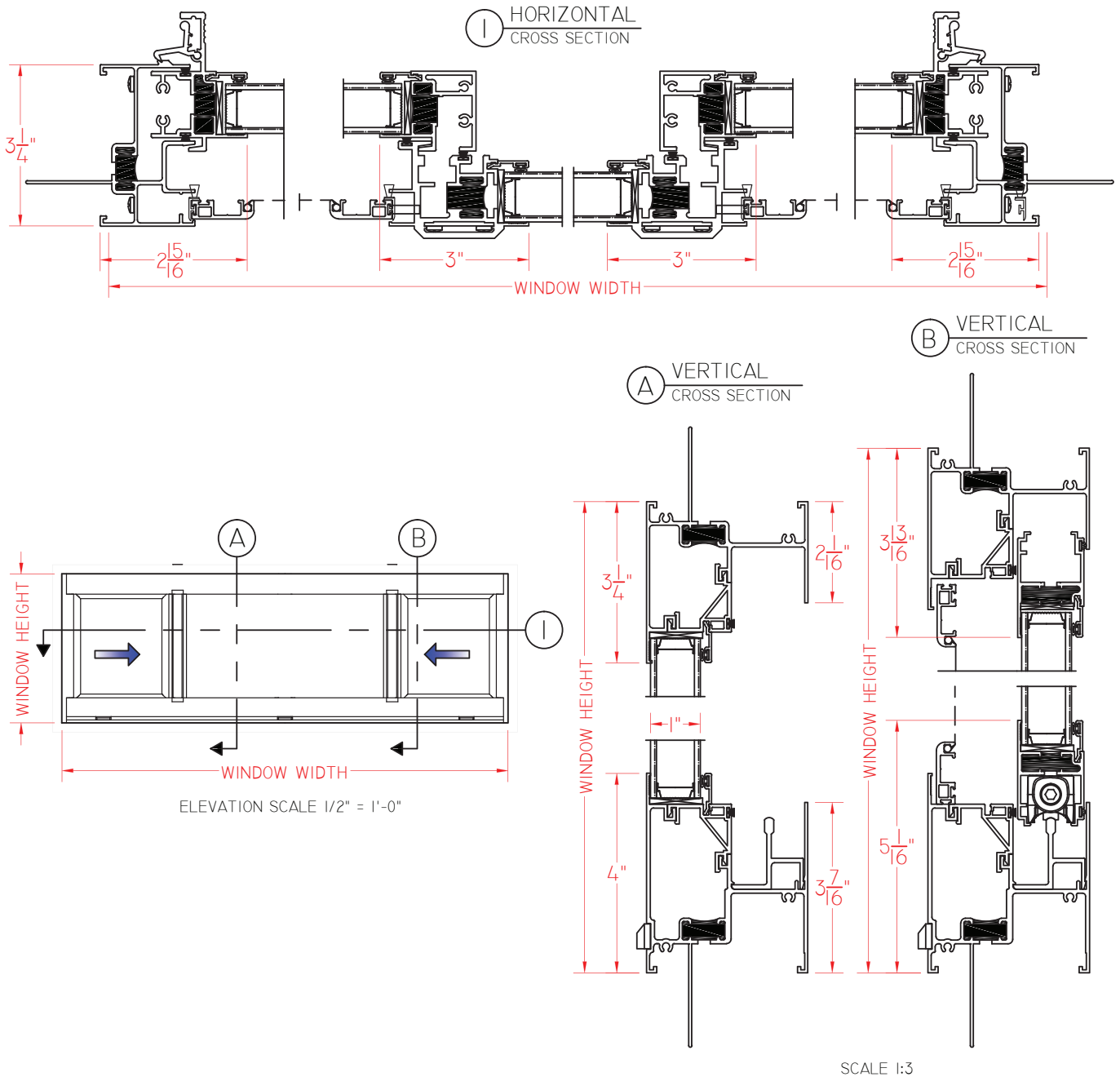

Our products are tested to the standards of and certified by the American Architectural Manufacturer's Association, the National Fenestration Rating Council and the Window & Door Manufacturers Association.



**QUAKER**  
COMMERCIAL WINDOWS AND DOORS



**QUAKER**  
COMMERCIAL WINDOWS AND DOORS



**emerge** **E350 Series**  
**CW-PG50**  
**3 1/4" Frame Depth**  
**Horizontal Slider**

# E350 END VENT SLIDER WITHOUT NAILING FIN

This document contains confidential and proprietary information intended for the private use of Quaker.  
© 2016 Quaker Window Products Co., INC. All rights reserved.  
Quaker reserves the right to change any/all designs without notice. Due to periodic re-certification requirements, result shown may vary.

① HORIZONTAL CROSS SECTION

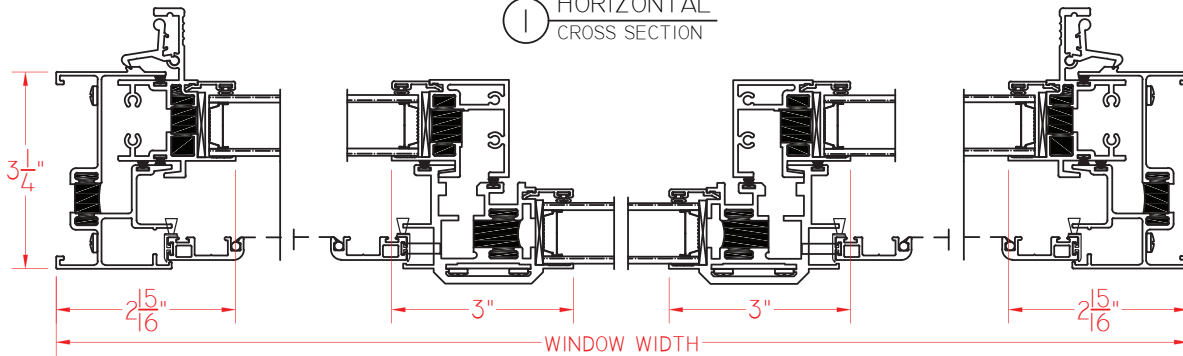

Ⓐ VERTICAL CROSS SECTION

Ⓑ VERTICAL CROSS SECTION

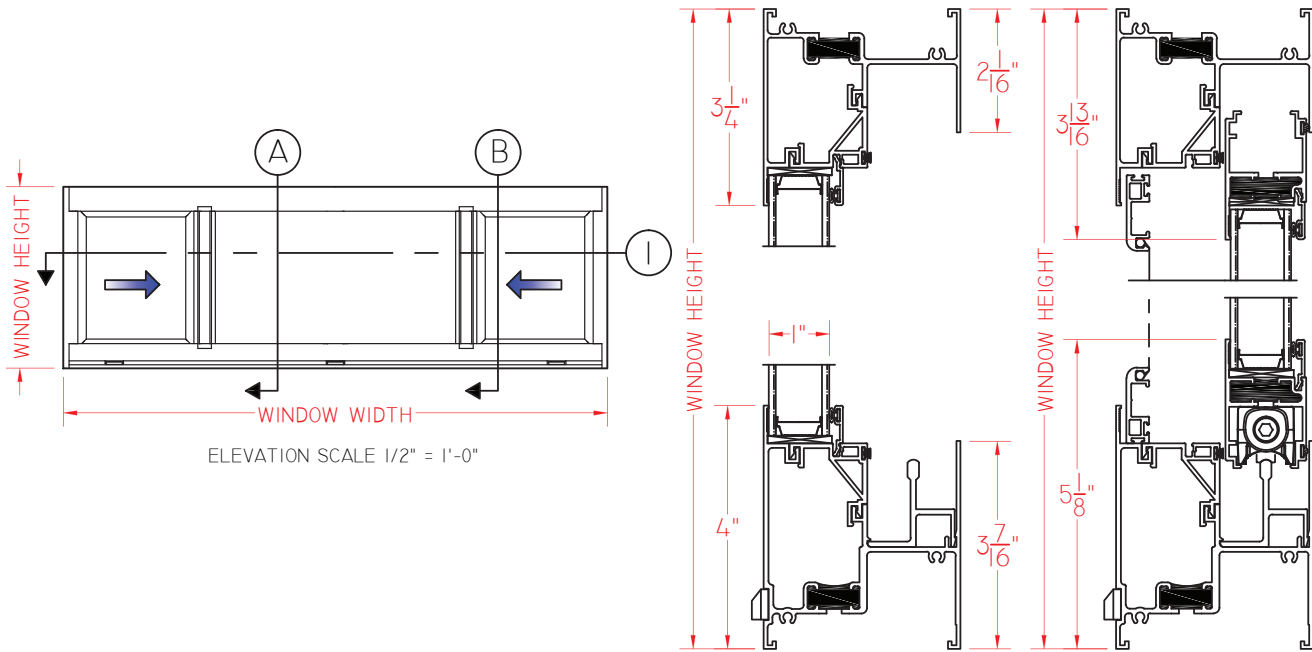

SCALE 1:3

Our products are tested to the standards of and certified by the American Architectural Manufacturer's Association, the National Fenestration Rating Council and the Window & Door Manufacturers Association.



**QUAKER**  
COMMERCIAL WINDOWS AND DOORS