

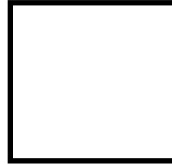

QUAKER
COMMERCIAL WINDOWS AND DOORS



**H500 Series
AW-PG40
3 1/4" Frame Depth
Picture Window (Fixed)**

H500 SERIES PICTURE WINDOW (FIXED)

The Quaker Historical H500 Series Casement window is ideal for a variety of applications including - Historical, Landmarks, Institutions, Education, Apartments and Assisted Living.

FEATURES

- ◇ **Commercial Framing System**
 - 3 1/4" main frame
 - 0.062" wall thickness of interior and exterior walls
- ◇ **Enhanced Design**
 - Azon pour and debridge thermal break is 1/2" wide in all main frame and vent rail extrusions
- ◇ **Glazing**
 - 3/8" insulated glass

OPTIONS

- ◇ **Available Configurations**
 - Wire frame capabilities
- ◇ **Muntin Choices**
 - Internal or simulated divided lites available
- ◇ **Nailing Fin**
- ◇ **Glazing**
 - Capillary tubes
 - Argon gas
 - Wide variety of glazing, tinting and thickness options
- ◇ **Panning & Trim Choices**
 - Wide variety of panning, receptor and trim available
- ◇ **Mulling**
 - Wide variety of structural mulls

BENEFITS

- ◇ The capacity to match exterior colors for unique project facades
- ◇ The ability to facilitate large sizes for taller and wider window openings
- ◇ Historically accurate panning and trim styles to help your project meet Historic Preservation codes

PERFORMANCE

- ◇ Structural & Thermal (test reports or thermal simulations available upon request)

Model	Picture Window (Fixed)
AAMA/WDMA/CSA 101/I.S.2/A440-08 Rating	AW-PG40
Structural Load P.S.F.	60.15
Air at 50 MPH (cfm/ft ²)	0.01
Water (No Penetration) P.S.F.	8.15
U-Value (with Low-E and Argon)	0.32-0.42
SHGC (with Low-E and Argon)	0.15-0.33

Window test size: 60" x 99"



Our products are tested to the standards of and certified by the American Architectural Manufacturer's Association, the National Fenestration Rating Council and the Window & Door Manufacturers Association.



QUAKER
COMMERCIAL WINDOWS AND DOORS

ARCHITECTURAL PAINT COATINGS AND FINISHES

◇ Baked on powder coat finish meets ANSA/AAMA 2604 specs and is available in unlimited colors

- 11 Popular Colors

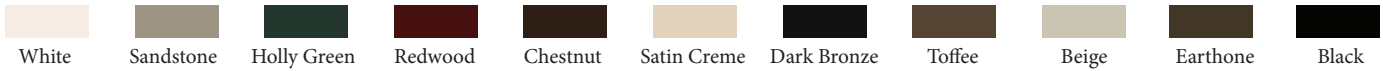

- 19 Impressive Colors

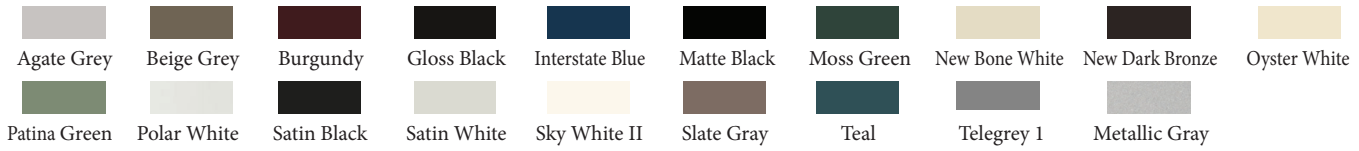

- 7 Resemble Colors (painted finish resembling anodized)



- Unlimited Custom Colors

* Printed colors shown here may not accurately depict actual painted colors. Color samples are available upon request.

◇ ANSA/AAMA 2605 powder coat finishes

◇ AAMA 611-98 Class I clear and tinted anodized finishes

Our products are tested to the standards of and certified by the American Architectural Manufacturer's Association, the National Fenestration Rating Council and the Window & Door Manufacturers Association.



QUAKER
COMMERCIAL WINDOWS AND DOORS



QUAKER
COMMERCIAL WINDOWS AND DOORS



**H500 Series
AW-PG40
3 1/4" Frame Depth
Picture Window (Fixed)**

H500 PW

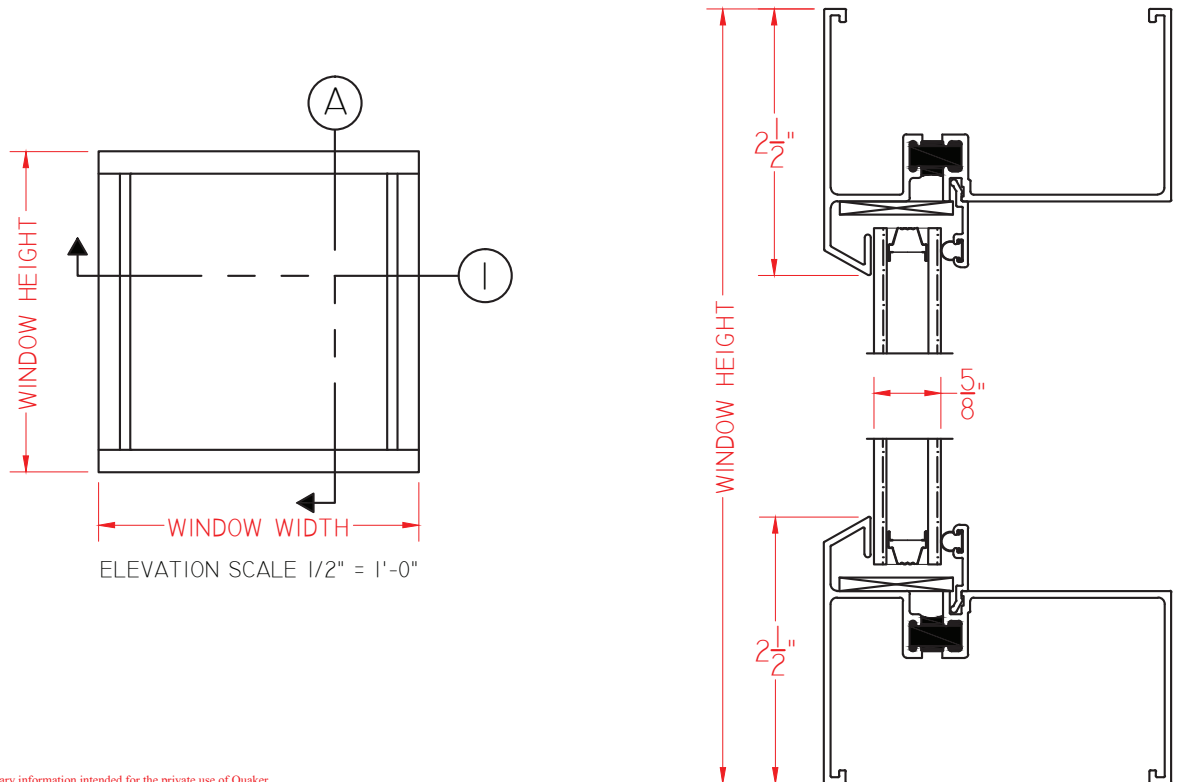
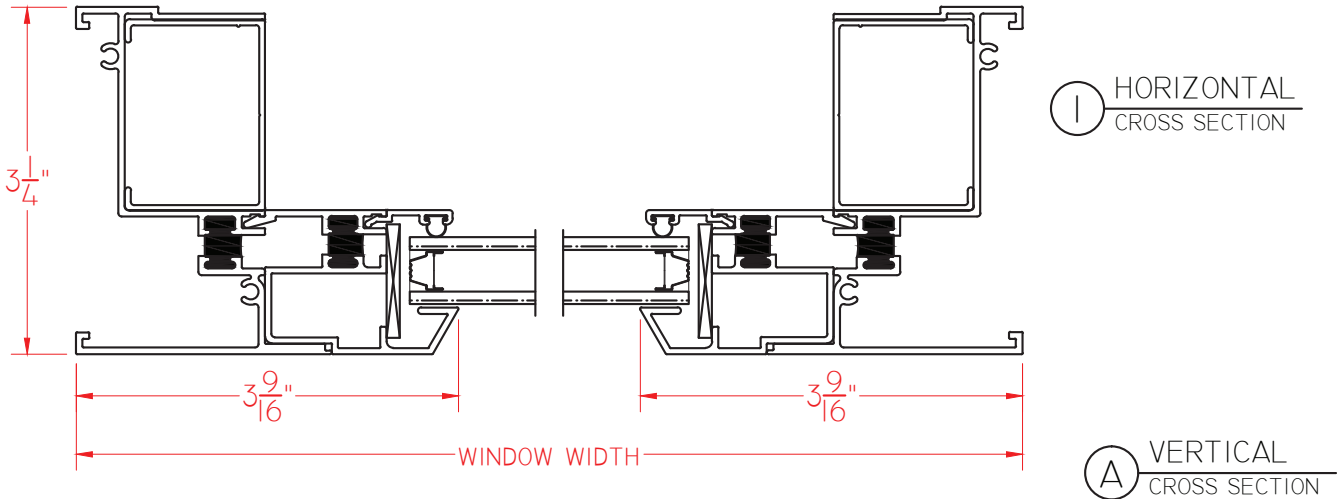

This document contains confidential and proprietary information intended for the private use of Quaker.
© 2016 Quaker Window Products Co., INC. All rights reserved.
Quaker reserves the right to change any/all designs without notice. Due to periodic re-certification requirements, result shown may vary.

H500 DIRECT SET PICTURE 02.04.2015 VERSION 1.0

SCALE 1:2

Our products are tested to the standards of and certified by the American Architectural Manufacturer's Association, the National Fenestration Rating Council and the Window & Door Manufacturers Association.



QUAKER
COMMERCIAL WINDOWS AND DOORS