



QUAKER
COMMERCIAL WINDOWS AND DOORS



**K300 Series
HC50**

**3 1/4" Frame Depth
Picture Window (Fixed)**

K300 SERIES PICTURE WINDOW (FIXED)

The Quaker Keystone K300 Series Horizontal Slider window is ideal for a variety of applications including - Hospitality, Institutions, Education, Apartments, Assisted Living and Housing Authority.

FEATURES

- ◇ **Commercial Framing System**
 - 3 1/4" main frame
 - 0.062" wall thickness of frame
- ◇ **Enhanced Design**
 - Azon pour and debridge thermal break is 1/2" wide in all frame
 - Frame and sash mortised and joined with screw fasteners
- ◇ **Glazing**
 - 1" insulated glass

BENEFITS

- ◇ The capacity to match exterior colors for unique project facades
- ◇ The ability to facilitate large sizes for taller and wider window openings

OPTIONS

- ◇ **Available Configurations**
 - Fixed
 - Geometric shapes
- ◇ **Muntin Choices**
 - Internal or simulated divided lites available
- ◇ **Nailing Fin**
- ◇ **Glazing**
 - Capillary tubes
 - Argon gas
 - Wide variety of glazing, tinting and thickness options
- ◇ **Panning & Trim Choices**
 - Wide variety of panning, receptor and trim available
- ◇ **Mulling**
 - Wide variety of structural mulls
- ◇ **Specialty**
 - Attached exterior or interior storm window
 - Extension jambs
 - Louver

PERFORMANCE

- ◇ Structural & Thermal (test reports or thermal simulations available upon request)

Model	Picture Window (Fixed)
AAMA/WDMA/CSA 101/I.S.2/A440-08 Rating	HC50
Structural Load P.S.F.	75
Air at 50 MPH (cfm/ft ²)	0.003
Water (No Penetration) P.S.F.	7.50
U-Value (with Low-E and Argon)	0.27-0.33
SHGC (with Low-E and Argon)	0.16-0.37

Window test size: 72" x 72"

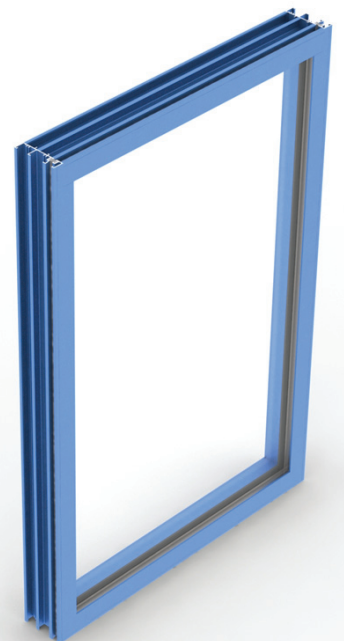

Our products are tested to the standards of and certified by the American Architectural Manufacturer's Association, the National Fenestration Rating Council and the Window & Door Manufacturers Association.



QUAKER
COMMERCIAL WINDOWS AND DOORS

ARCHITECTURAL PAINT COATINGS AND FINISHES

◇ Baked on powder coat finish meets ANSA/AAMA 2604 specs and is available in unlimited colors

- 11 Popular Colors

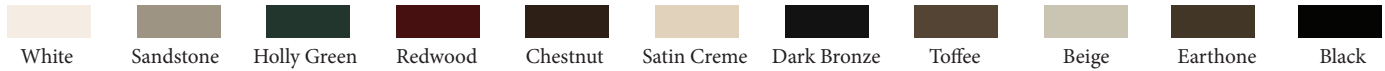

- 19 Impressive Colors



- 7 Resemble Colors (painted finish resembling anodized)



- Unlimited Custom Colors

* Printed colors shown here may not accurately depict actual painted colors. Color samples are available upon request.

◇ ANSA/AAMA 2605 powder coat finishes

◇ AAMA 611-98 Class I clear and tinted anodized finishes

Our products are tested to the standards of and certified by the American Architectural Manufacturer's Association, the National Fenestration Rating Council and the Window & Door Manufacturers Association.



QUAKER
COMMERCIAL WINDOWS AND DOORS



QUAKER
COMMERCIAL WINDOWS AND DOORS



**K300 Series
HC50
3 1/4" Frame Depth
Picture Window (Fixed)**

K300 FIXED WITH NAILING FIN

This document contains confidential and proprietary information intended for the private use of Quaker.
© 2016 Quaker Window Products Co., INC. All rights reserved.
Quaker reserves the right to change any/all designs without notice. Due to periodic re-certification requirements, result shown may vary.

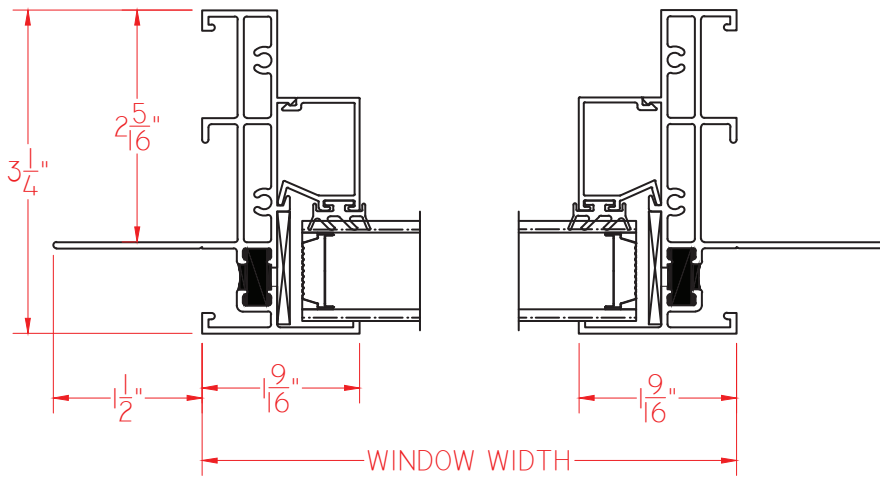

Ⓐ VERTICAL CROSS SECTION

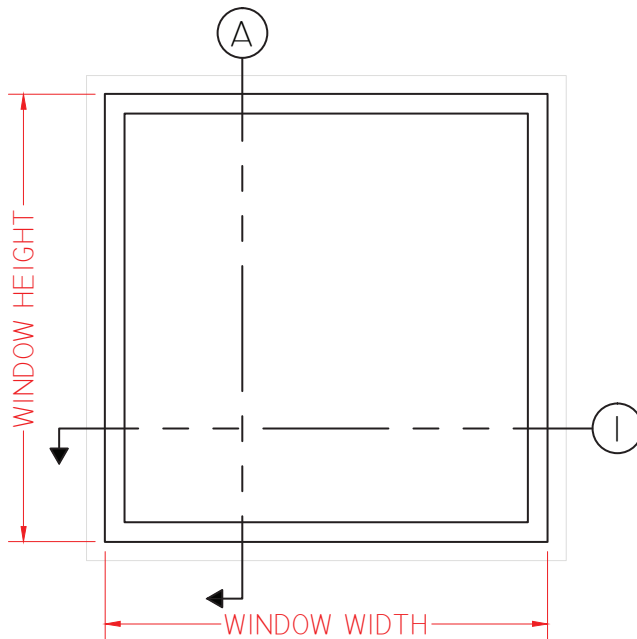
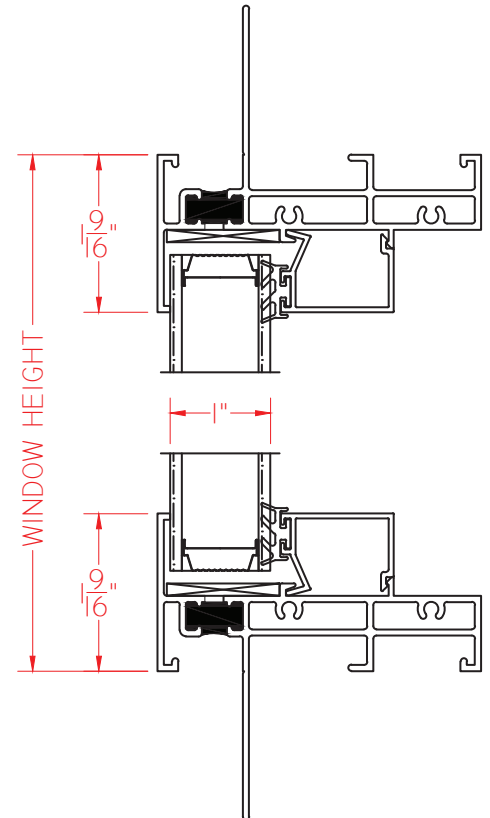

ELEVATION SCALE 3/4" = 1'-0"

SCALE 1:2

Our products are tested to the standards of and certified by the American Architectural Manufacturer's Association, the National Fenestration Rating Council and the Window & Door Manufacturers Association.



QUAKER
COMMERCIAL WINDOWS AND DOORS



QUAKER
COMMERCIAL WINDOWS AND DOORS



**K300 Series
HC50**

**3 1/4" Frame Depth
Picture Window (Fixed)**

K300 FIXED WITHOUT NAILING FIN

This document contains confidential and proprietary information intended for the private use of Quaker.
© 2016 Quaker Window Products Co., INC. All rights reserved.
Quaker reserves the right to change any/all designs without notice. Due to periodic re-certification requirements, result shown may vary.

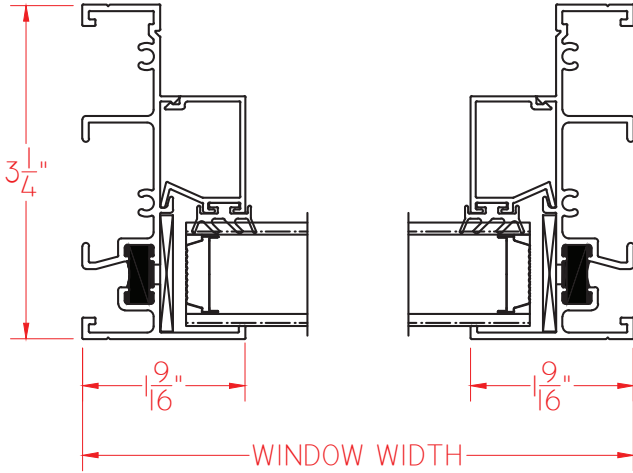

① HORIZONTAL
CROSS SECTION

Ⓐ VERTICAL
CROSS SECTION

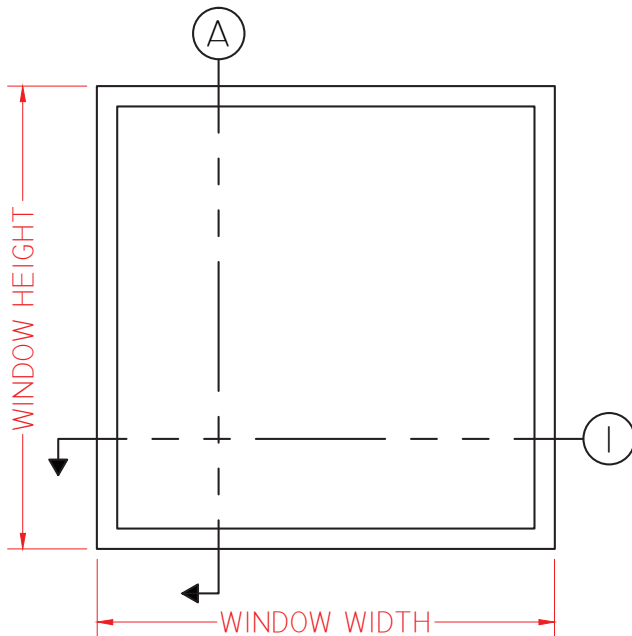

ELEVATION SCALE 3/4" = 1'-0"

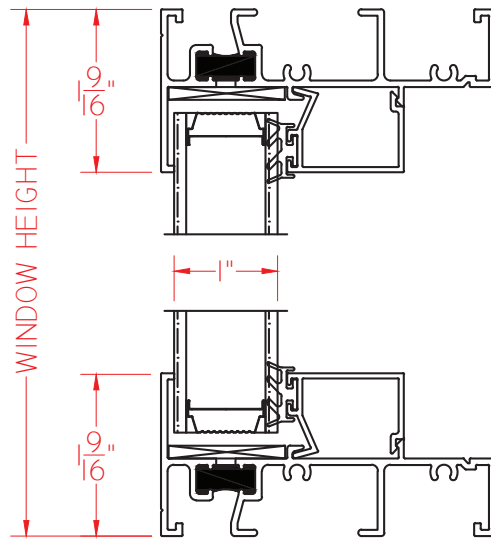

SCALE 1:2

Our products are tested to the standards of and certified by the American Architectural Manufacturer's Association, the National Fenestration Rating Council and the Window & Door Manufacturers Association.



QUAKER
COMMERCIAL WINDOWS AND DOORS



QUAKER
COMMERCIAL WINDOWS AND DOORS



**K300 Series
HC50**

**3 1/4" Frame Depth
Picture Window (Fixed)**

K300 FIXED GEOMETRICS

This document contains confidential and proprietary information intended for the private use of Quaker.
© 2016 Quaker Window Products Co., INC. All rights reserved.
Quaker reserves the right to change any/all designs without notice. Due to periodic re-certification requirements, result shown may vary.

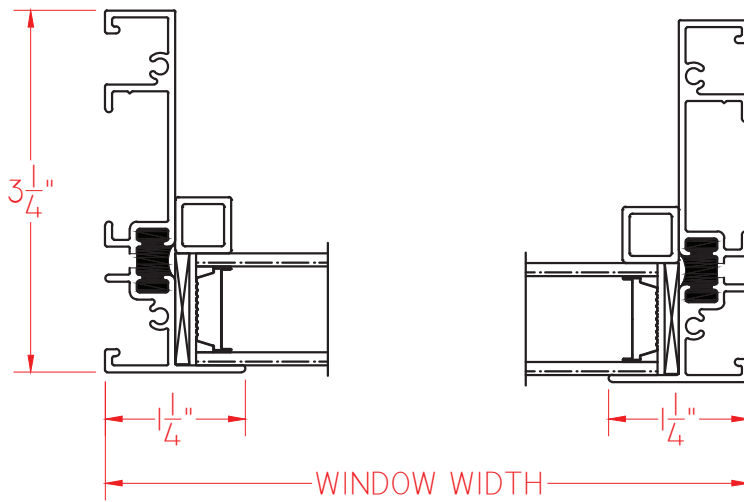

① HORIZONTAL
CROSS SECTION

Ⓐ VERTICAL
CROSS SECTION

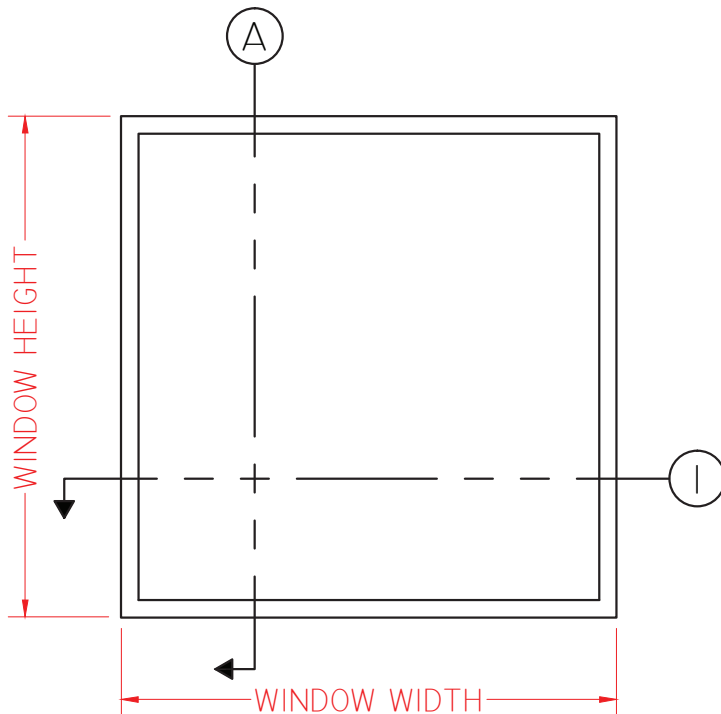

ELEVATION SCALE 3/4" = 1'-0"

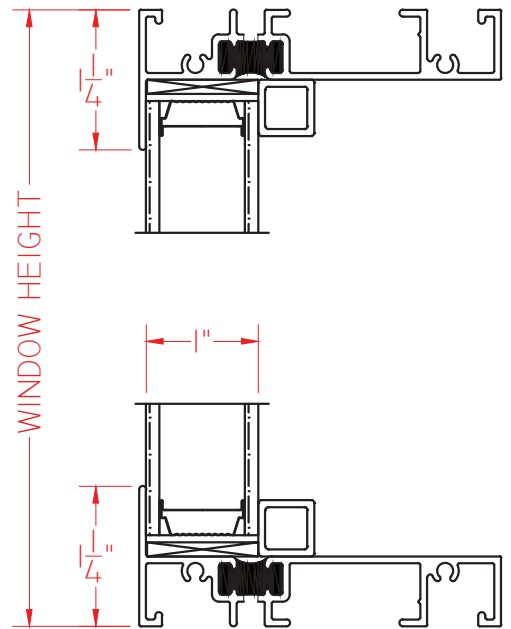

SCALE 1:2

Our products are tested to the standards of and certified by the American Architectural Manufacturer's Association, the National Fenestration Rating Council and the Window & Door Manufacturers Association.



QUAKER
COMMERCIAL WINDOWS AND DOORS



QUAKER
COMMERCIAL WINDOWS AND DOORS



K300 Series
HC50
3 1/4" Frame Depth
Picture Window (Fixed)

K300 FIXED DOUBLE JAMB (V)

This document contains confidential and proprietary information intended for the private use of Quaker.
© 2016 Quaker Window Products Co., INC. All rights reserved.
Quaker reserves the right to change any/all designs without notice. Due to periodic re-certification requirements, result shown may vary.

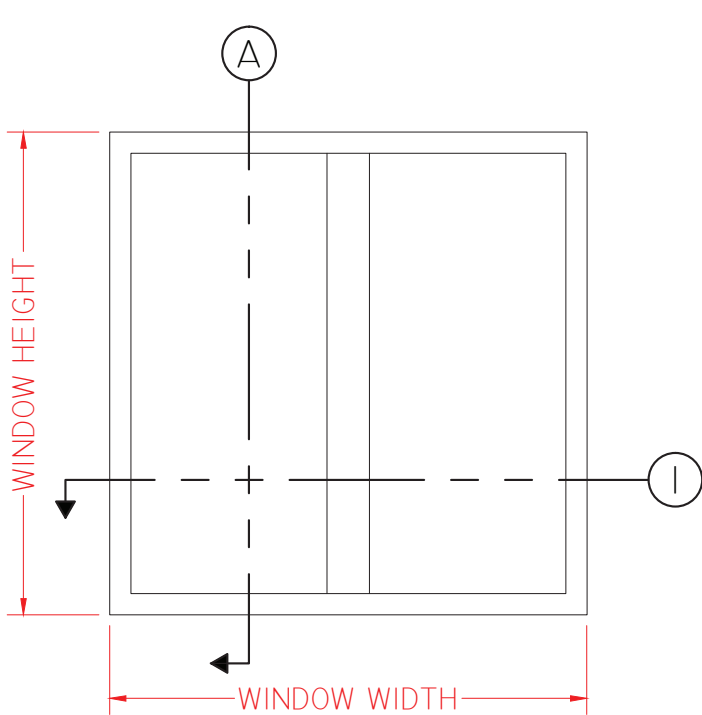
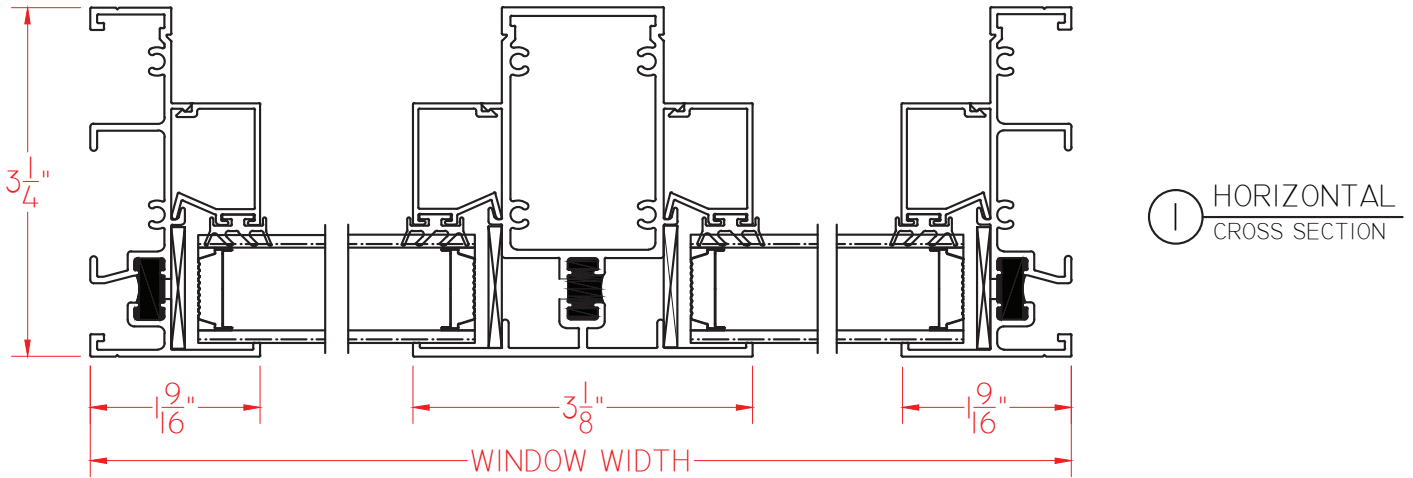

ELEVATION SCALE 3/4" = 1'-0"

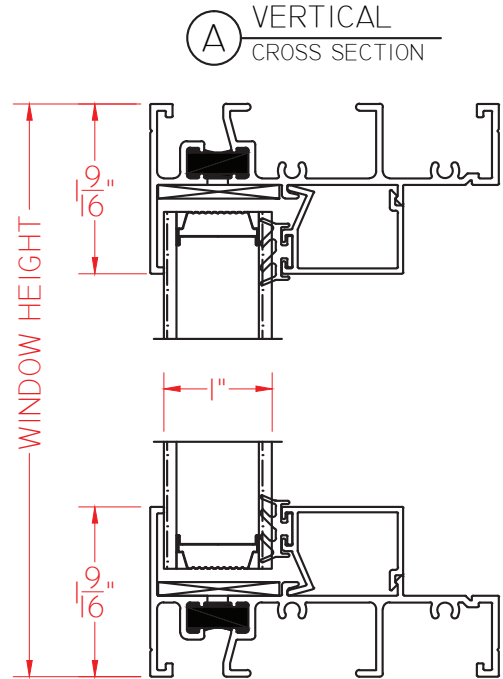

SCALE 1:2

Our products are tested to the standards of and certified by the American Architectural Manufacturer's Association, the National Fenestration Rating Council and the Window & Door Manufacturers Association.



QUAKER
COMMERCIAL WINDOWS AND DOORS



QUAKER
COMMERCIAL WINDOWS AND DOORS



K300 Series
HC50
3 1/4" Frame Depth
Picture Window (Fixed)

K300 FIXED DOUBLE JAMB (H)

This document contains confidential and proprietary information intended for the private use of Quaker.
© 2016 Quaker Window Products Co., INC. All rights reserved.
Quaker reserves the right to change any/all designs without notice. Due to periodic re-certification requirements, result shown may vary.

① HORIZONTAL CROSS SECTION

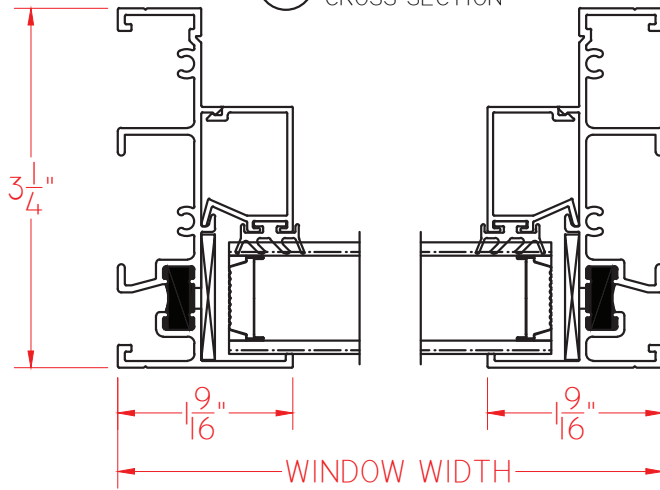

Ⓐ VERTICAL CROSS SECTION

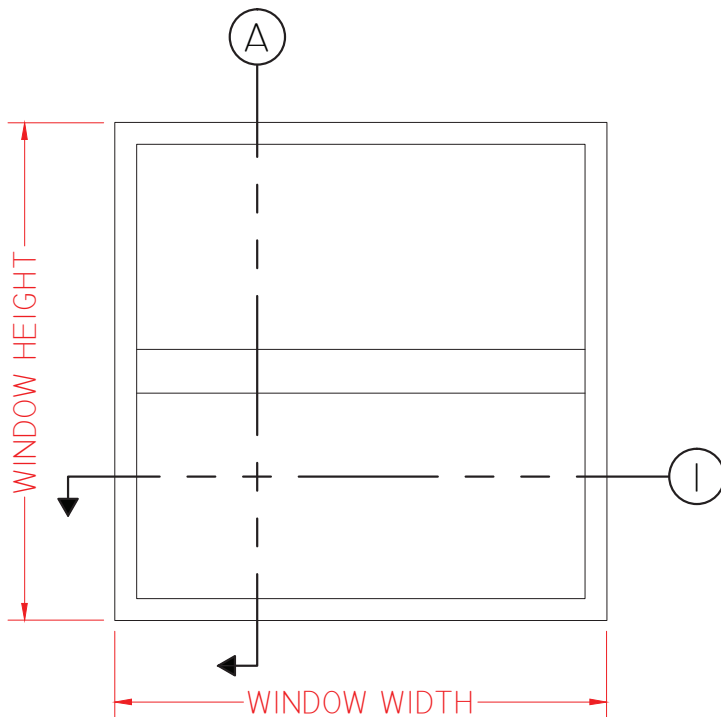
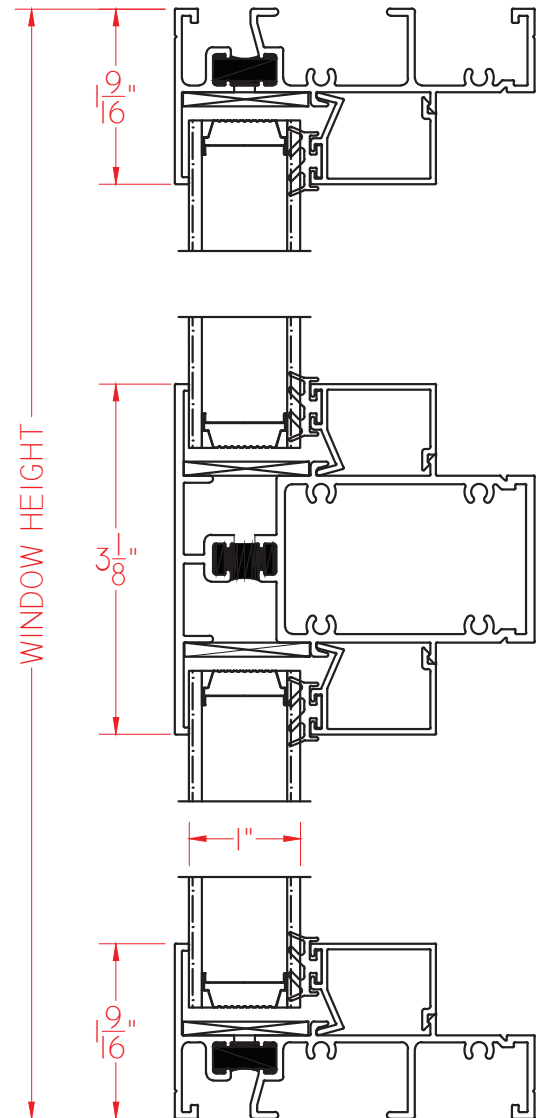

ELEVATION SCALE 3/4" = 1'-0"

SCALE 1:3

Our products are tested to the standards of and certified by the American Architectural Manufacturer's Association, the National Fenestration Rating Council and the Window & Door Manufacturers Association.



QUAKER
COMMERCIAL WINDOWS AND DOORS