



Q213
Rating
4 1/2" Frame Depth
Hinged Entry Door

Q213 SERIES HINGED ENTRY DOOR

The Quaker Q213 Series Hinged Entry door is ideal for a variety of applications including - Institutions, Education, Apartments and Assisted Living.

FEATURES

- ◇ **Commercial Framing System**
 - 4 1/2' main frame
 - Major portions of door members to contain 0.125" wall thickness
- ◇ **Thermally Enhanced Design**
 - Interlocking corner block construction
 - Narrow or Medium width stiles
- ◇ **Glazing**
 - Glazing pocket can accommodate up from 1/4" single glaze to 1" insulated glass
- ◇ **Hardware**
 - Contemporary handle set with a multi-point locking system for supreme protection
 - Minimum of two adjustable hinges with more added if panel size calls for additional support

OPTIONS

- ◇ **Available Configurations**
 - Single Panel
 - Dual Panel
 - Matching transoms and sidelites
 - Standard or custom sizing
- ◇ **Muntin Choices**
 - Internal or simulated divided lites available
- ◇ **Hardware**
 - Mid-panel flush panic hardware
 - Rim-mounted Pad panic exit device
 - Electric strikes
 - Pivot, butt or continuous hinges
 - 10" bottom rail for A.D.A modifications
- ◇ **Glazing**
 - Capillary tubes
 - Argon gas
 - Wide variety of glazing, tinting and thickness options
- ◇ **Panning & Trim Choices**
 - Wide variety of panning, receptor and trim available

BENEFITS

- ◇ The capacity to match exterior colors for unique project facades
- ◇ Get the view that's best for your application with stile widths range that from Narrow to Medium

PERFORMANCE

- ◇ Structural & Thermal (test reports or thermal simulations available upon request)

Model	Q213	
	Single Panel	Dual Panel
AAMA/WDMA/CSA 101/I.S.2/A440-08 Rating		
Structural Load P.S.F.		
Air at 50 MPH (cfm/ft ²)		
Water (No Penetration) P.S.F.		
U-Value		
SHGC		
Door test size		

Our products are tested to the standards of and certified by the American Architectural Manufacturer's Association, the National Fenestration Rating Council and the Window & Door Manufacturers Association.



ARCHITECTURAL PAINT COATINGS AND FINISHES

◇ Baked on powder coat finish meets ANSA/AAMA 2604 specs and is available in unlimited colors

- 11 Popular Colors

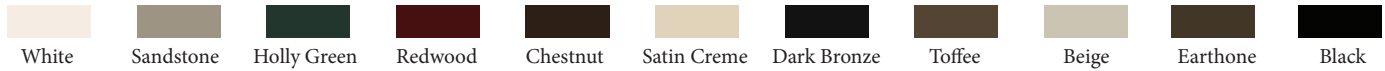

- 19 Impressive Colors

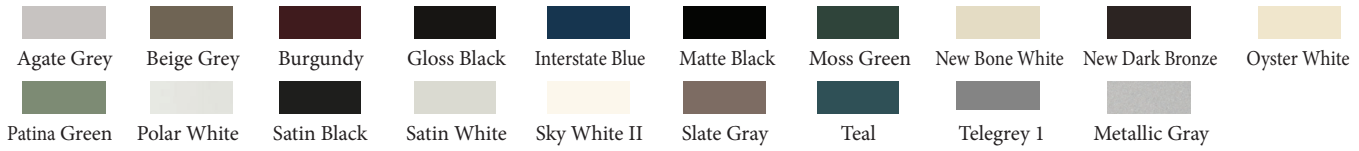

- 7 Resemble Colors (painted finish resembling anodized)



- Unlimited Custom Colors

* Printed colors shown here may not accurately depict actual painted colors. Color samples are available upon request.

◇ ANSA/AAMA 2605 powder coat finishes

◇ AAMA 611-98 Class I clear and tinted anodized finishes

Our products are tested to the standards of and certified by the American Architectural Manufacturer's Association, the National Fenestration Rating Council and the Window & Door Manufacturers Association.



Standard Entrances

Series Q213 Narrow Stile

Standard Details

Scale: 3" = 1'-0"

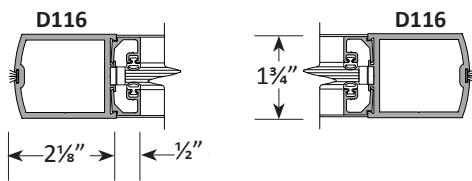

Single door

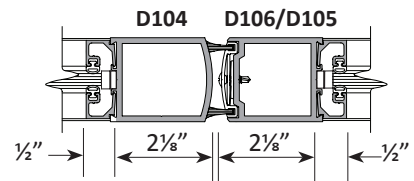

Meeting stiles for pair of doors

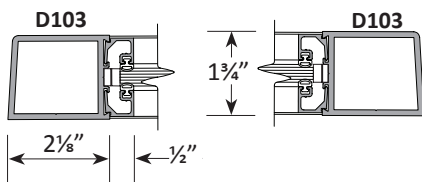

Single door

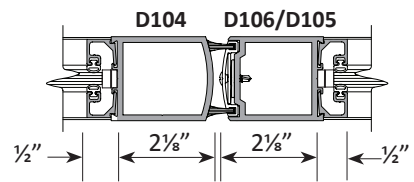

Meeting stiles for pair of doors

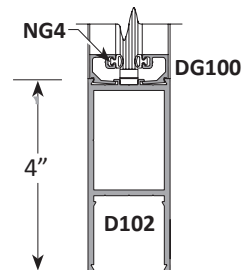
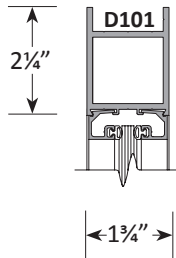
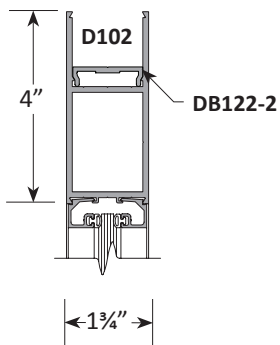

Standard Entrances

Series Q213

Accessories and Options

Scale: 3" = 1'-0"

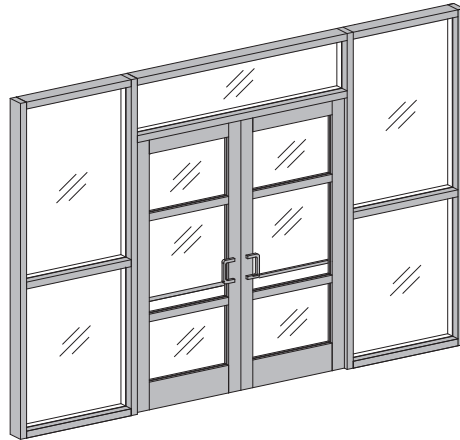

Door Mid-Rail

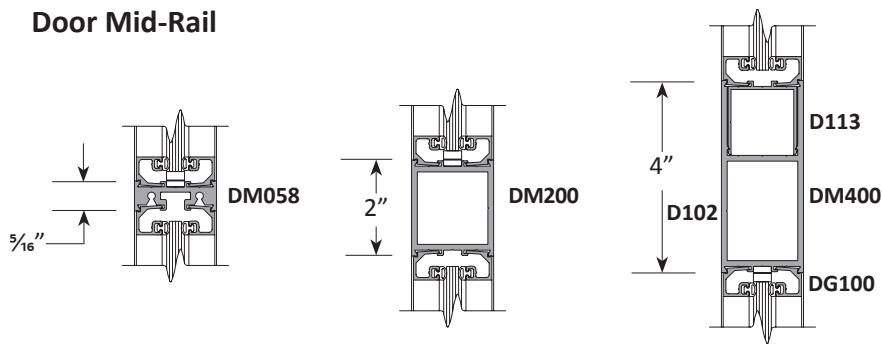

Thresholds

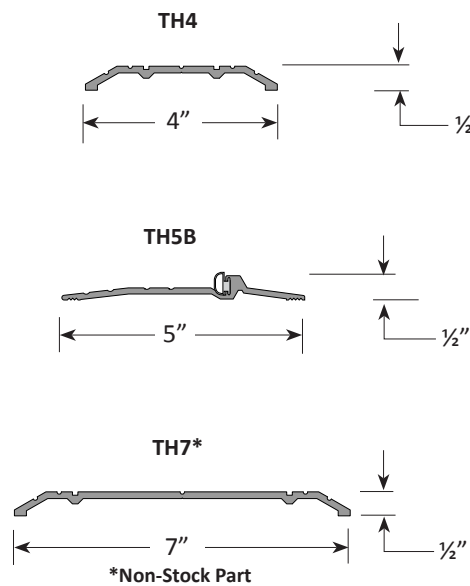

Glazing Options

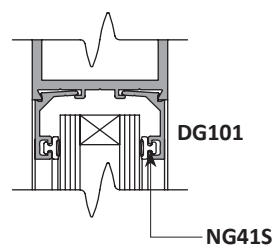

Bottom Rail with Weather Sweep

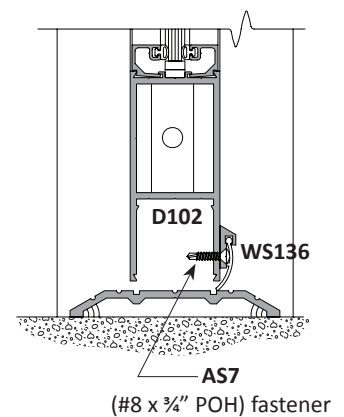

Standard Entrance

Series Q213

Selection Guide

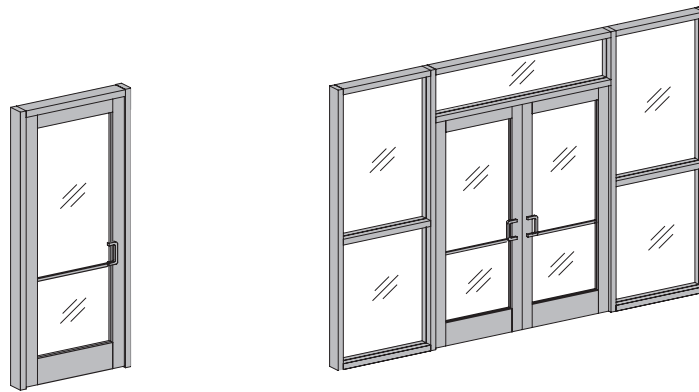

Note: Illustration shows are for demonstration purposes only and may not accurately depict sight lines for Q213 Series door.

Aluminum Entrance Doors	VERTICAL STILE	TOP RAIL	BOTTOM RAIL	RECOMMENDED LIMITATIONS	TRAFFIC APPLICATION
Series Q213 Narrow Stile	2 1/8"	2 1/4"	4"	3'-3" x 8'-0"	Normal

Note: Entrances exceeding 3'-6" x 7'-6" in height require an intermediate butt hinge or pivot.

COMMON ENTRANCE AND FRAME DESCRIPTIONS

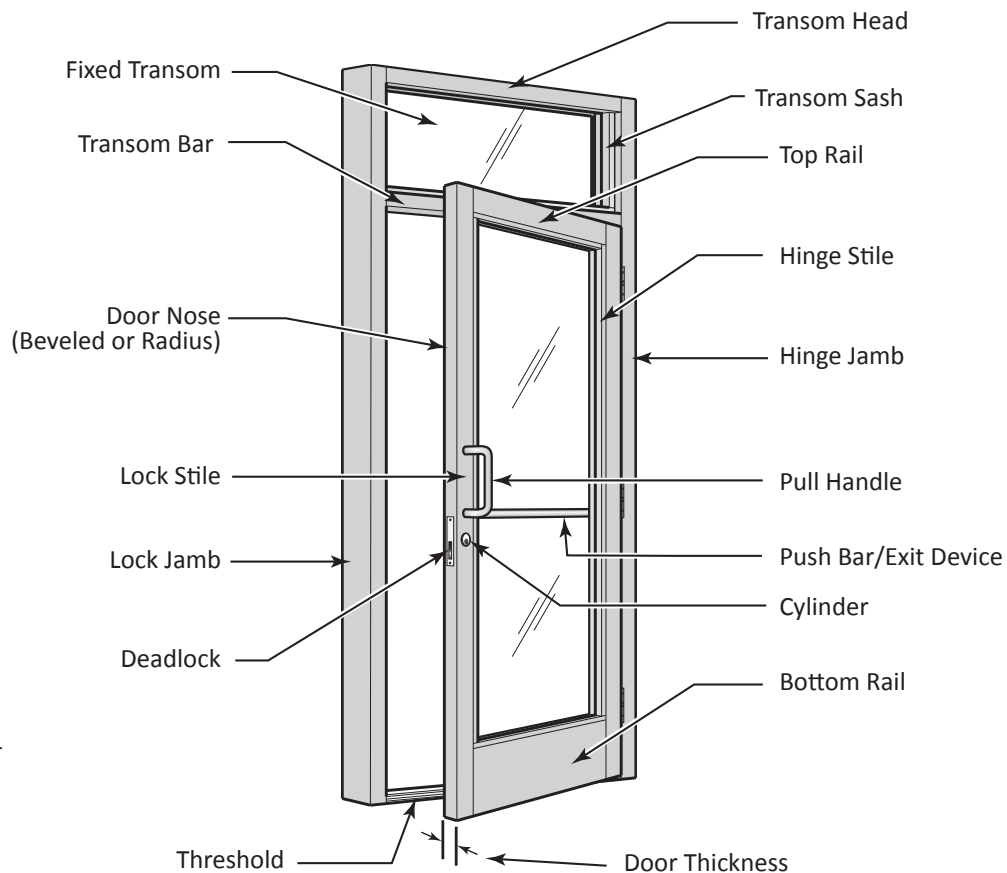

Note: Illustration shown is for demonstration purposes only and may not accurately depict sight lines for Q213 Series door.