



**QUAKER**  
COMMERCIAL WINDOWS AND DOORS



Traditional  
SERIES

**T200 Series  
CW-PG50/CW-PG80  
2 3/8" Frame Depth  
Picture Window (Fixed)**

## T200 SERIES PICTURE WINDOW (FIXED)

The Quaker Traditional T200 Series Picture window is ideal for a variety of applications including - Energy Efficient, Institutions, Education, Apartments, Assisted Living and Housing Authority.

### FEATURES

- ◇ **Commercial Framing System**
  - 2 3/8" main frame
  - 0.090" wall thickness of interior and exterior walls, 0.078" wall thickness elsewhere
- ◇ **Enhanced Design**
  - Azon pour and debridge thermal break is 1/2" wide in all main frame and vent rail extrusions
- ◇ **Glazing**
  - 1" insulated glass

### OPTIONS

- ◇ **Available Configurations**
  - Direct Set
- ◇ **Muntin Choices**
  - Internal or simulated divided lites available
- ◇ **Nailing Fin**
- ◇ **Glazing**
  - Capillary tubes
  - Argon gas
  - Wide variety of glazing, tinting and thickness options
- ◇ **Panning & Trim Choices**
  - Wide variety of panning, receptor and trim available
- ◇ **Mulling**
  - Wide variety of structural mulls

### BENEFITS

- ◇ The capacity to match exterior colors for unique project facades
- ◇ The ability to facilitate large sizes for taller and wider window openings

### PERFORMANCE

- ◇ Structural & Thermal (test reports or thermal simulations available upon request)

Model	Picture Window (Fixed)	
	CW-PG50	CW-PG80
AAMA/WDMA/CSA 101/IS.2/A440-08 Rating		
Structural Load P.S.F.	75.19	120.30
Air at 50 MPH (cfm/ft <sup>2</sup> )	0.01	-
Water (No Penetration) P.S.F.	12.11	-
U-Value (with Low-E and Argon)	0.26-0.32	
SHGC (with Low-E and Argon)	0.15-0.36	
Window Test Size	60" x 96"	60" x 60"



Our products are tested to the standards of and certified by the American Architectural Manufacturer's Association, the National Fenestration Rating Council and the Window & Door Manufacturers Association.



**QUAKER**  
COMMERCIAL WINDOWS AND DOORS

# ARCHITECTURAL PAINT COATINGS AND FINISHES

◇ Baked on powder coat finish meets ANSA/AAMA 2604 specs and is available in unlimited colors

- 11 Popular Colors

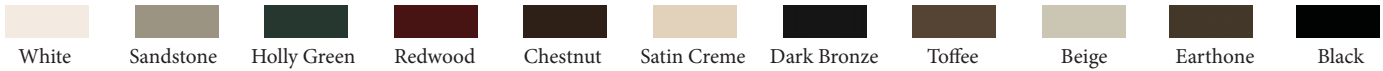

- 19 Impressive Colors

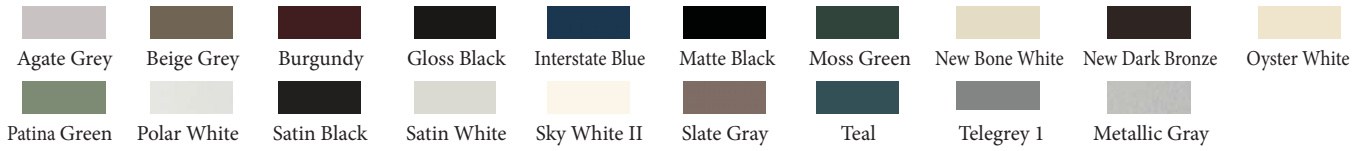

- 7 Resemble Colors (painted finish resembling anodized)



- Unlimited Custom Colors

\* Printed colors shown here may not accurately depict actual painted colors. Color samples are available upon request.

◇ ANSA/AAMA 2605 powder coat finishes

◇ AAMA 611-98 Class I clear and tinted anodized finishes

Our products are tested to the standards of and certified by the American Architectural Manufacturer's Association, the National Fenestration Rating Council and the Window & Door Manufacturers Association.



**QUAKER**  
COMMERCIAL WINDOWS AND DOORS



**QUAKER**  
COMMERCIAL WINDOWS AND DOORS



Traditional  
SERIES

**T200 Series**  
**CW-PG50/CW-PG80**  
**2 3/8" Frame Depth**  
**Picture Window (Fixed)**

**T200 FIXED**

This document contains confidential and proprietary information intended for the private use of Quaker.  
© 2016 Quaker Window Products Co., INC. All rights reserved.  
Quaker reserves the right to change any/all designs without notice. Due to periodic re-certification requirements, result shown may vary.

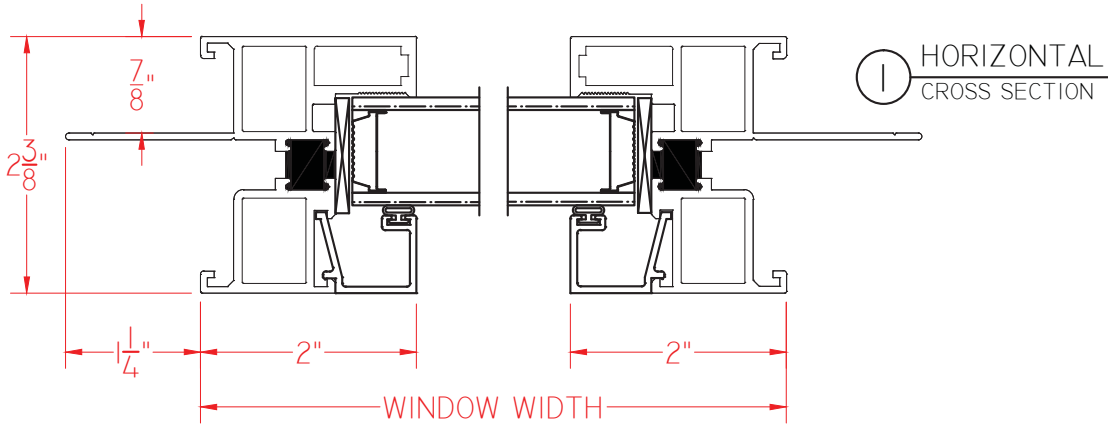

Ⓐ VERTICAL CROSS SECTION

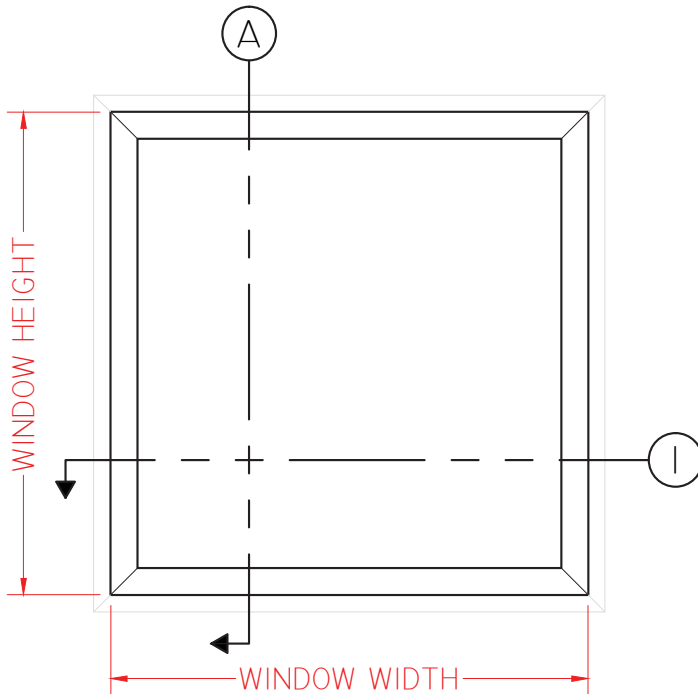

ELEVATION SCALE 3/4" = 1'-0"

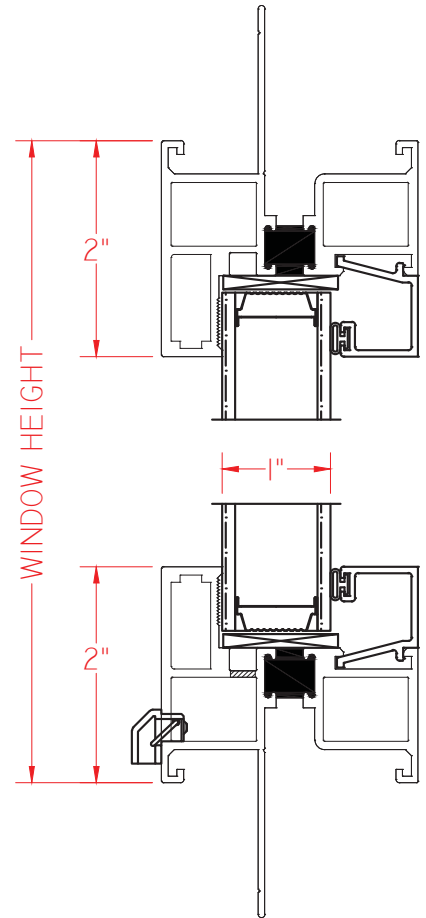

SCALE 1:2

Our products are tested to the standards of and certified by the American Architectural Manufacturer's Association, the National Fenestration Rating Council and the Window & Door Manufacturers Association.



**QUAKER**  
COMMERCIAL WINDOWS AND DOORS



**QUAKER**  
COMMERCIAL WINDOWS AND DOORS



Traditional  
SERIES

**T200 Series  
CW-PG50/CW-PG80  
2 3/8" Frame Depth  
Picture Window (Fixed)**

**T200 FIXED TRUE DIVIDED LITE (H)**

This document contains confidential and proprietary information intended for the private use of Quaker.  
© 2016 Quaker Window Products Co., INC. All rights reserved.  
Quaker reserves the right to change any/all designs without notice. Due to periodic re-certification requirements, result shown may vary.

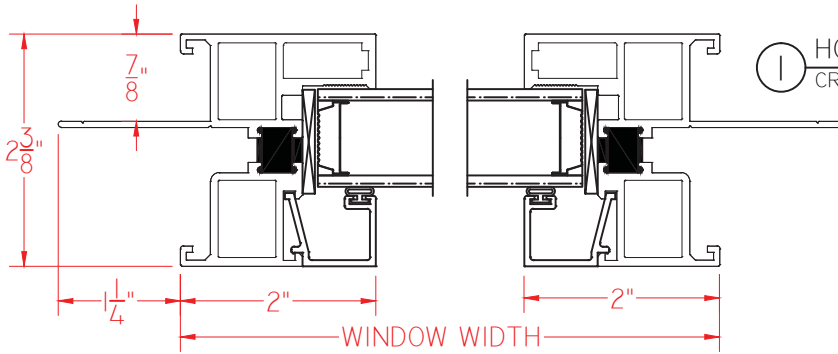

② VERTICAL CROSS SECTION

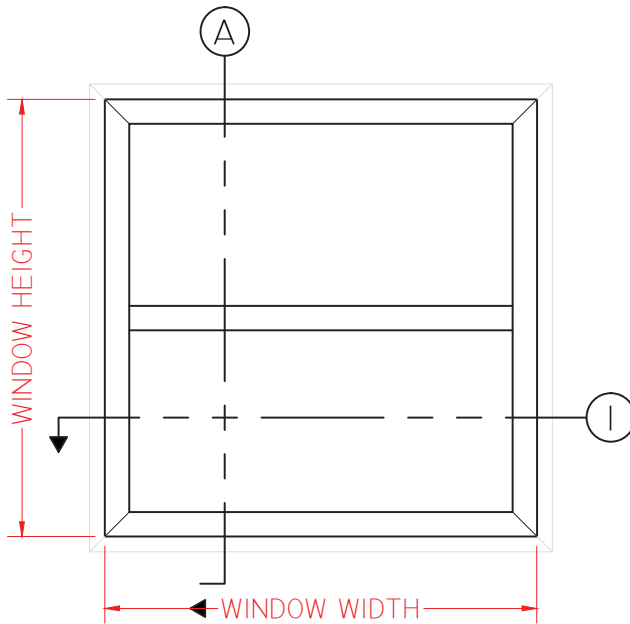
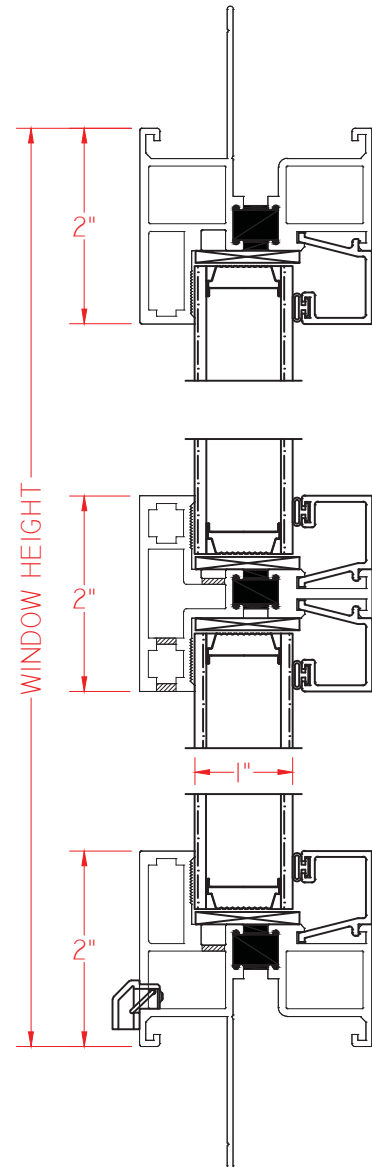

ELEVATION SCALE 3/4" = 1'-0"

SCALE 1:2

Our products are tested to the standards of and certified by the American Architectural Manufacturer's Association, the National Fenestration Rating Council and the Window & Door Manufacturers Association.



**QUAKER**  
COMMERCIAL WINDOWS AND DOORS



**QUAKER**  
COMMERCIAL WINDOWS AND DOORS



Traditional  
SERIES

**T200 Series**  
**CW-PG50/CW-PG80**  
**2 3/8" Frame Depth**  
**Picture Window (Fixed)**

**T200 FIXED TRUE DIVIDED LITE (V)**

This document contains confidential and proprietary information intended for the private use of Quaker.  
© 2016 Quaker Window Products Co., INC. All rights reserved.  
Quaker reserves the right to change any/all designs without notice. Due to periodic re-certification requirements, result shown may vary.

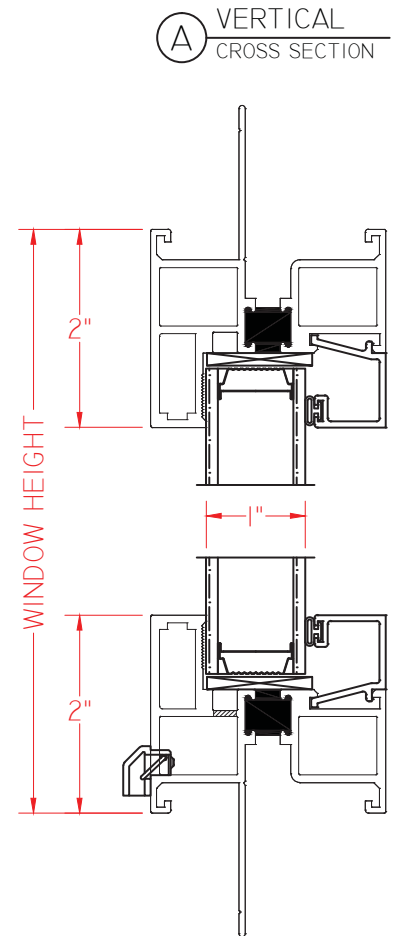
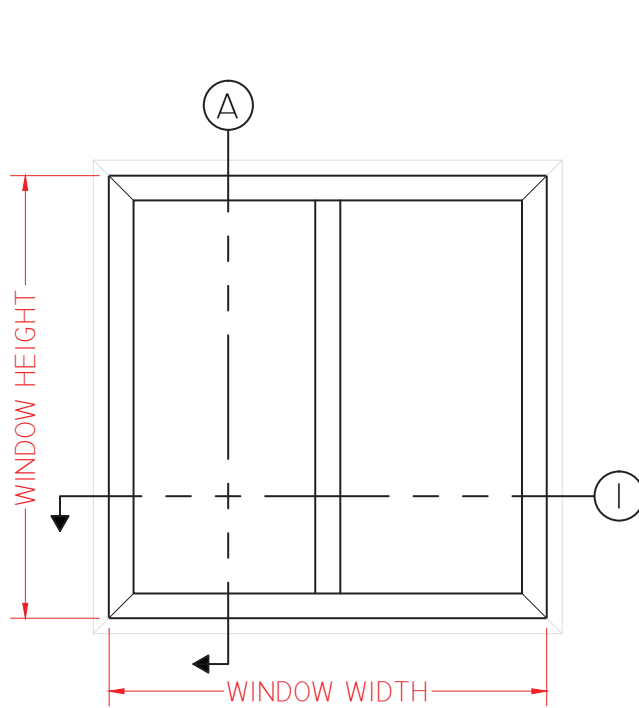
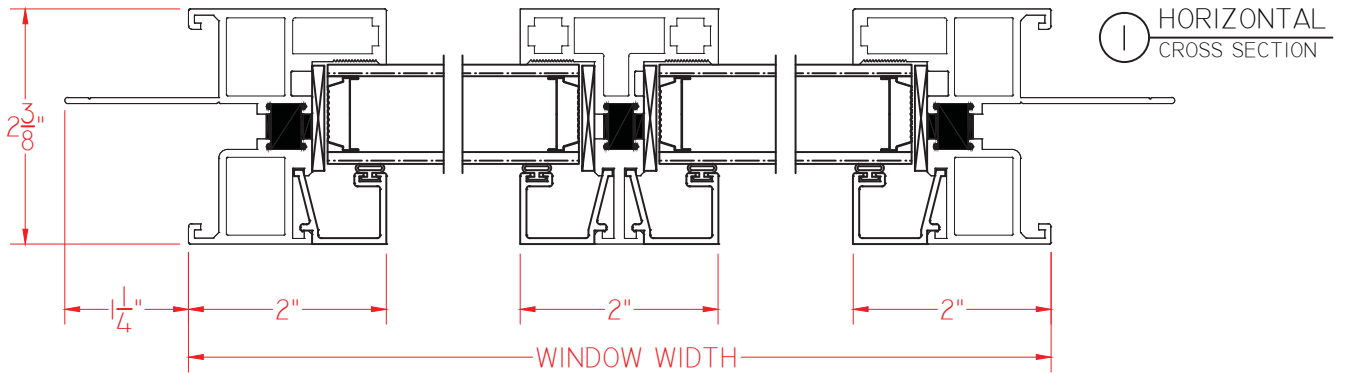

SCALE 1:2

Our products are tested to the standards of and certified by the American Architectural Manufacturer's Association, the National Fenestration Rating Council and the Window & Door Manufacturers Association.



**QUAKER**  
COMMERCIAL WINDOWS AND DOORS