

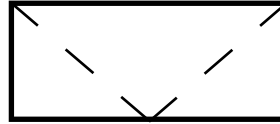

**QUAKER**  
COMMERCIAL WINDOWS AND DOORS



Traditional  
SERIES

**T600 Series**

**AW-PG70**

**3 1/4" Frame Depth  
Hopper (Project-in)**

## T600 SERIES HOPPER (PROJECT-IN)

The Quaker Traditional T600 Series Picture window is ideal for a variety of applications including - Institutions, Education, Apartments and Assisted Living.

### FEATURES

- ◇ **Commercial Framing System**
  - 3 1/4" main frame
  - 0.094" wall thickness of interior and exterior walls, 0.078" wall thickness elsewhere
- ◇ **Thermally Enhanced Design**
  - Azon pour and debridge thermal break is 1/2" wide in all main frame and vent rail extrusions
  - Assembled with heavy duty Monticelli cast aluminum corner keys
  - Mitered and pressure sealed internally with injected silicone through corner key passages. Wrap-around marine glazing
- ◇ **Glazing**
  - 1" insulated glass
- ◇ **Hardware**
  - Butt hinges or 4-Bar hinges
  - Low profile cam handle
  - Pole Operated handle
  - Custodial lock
- ◇ **Screen**
  - Extruded aluminum screen frame with BetterVue™ mesh

### OPTIONS

- ◇ **Available Configurations**
  - Project-in hopper
- ◇ **Muntin Choices**
  - Internal or simulated divided lites available
- ◇ **Limited travel hardware**
- ◇ **Nailing Fin**
- ◇ **Screen**
  - Extruded aluminum screen frame with aluminum wire mesh
  - Extruded aluminum screen frame with sunscreen mesh
  - Extruded aluminum screen frame with stainless steel 0.009" thickness mesh
- ◇ **Glazing**
  - Capillary tubes
  - Argon gas
  - Optional glazing stop to accept 1 3/8" (triple) glazing
  - Wide variety of glazing, tinting and thickness options
- ◇ **Panning & Trim Choices**
  - Wide variety of panning, receptor and trim available
- ◇ **Mulling**
  - Wide variety of structural mulls

### BENEFITS

- ◇ The capacity to match exterior colors for unique project facades
- ◇ The ability to facilitate large sizes for taller and wider window openings

### PERFORMANCE

- ◇ Structural & Thermal (test reports or thermal simulations available upon request)

Model	Hopper (Project-in)
AAMA/WDMA/CSA 101/I.S.2/A440-08 Rating	AW-PG70
Structural Load P.S.F.	105.26
Air at 50 MPH (cfm/ft <sup>2</sup> )	0.03
Water (No Penetration) P.S.F.	12.11
U-Value (with Low-E and Argon)	0.43-0.47
SHGC (with Low-E and Argon)	0.12-0.26



Window test size: 60" x 36"  
Operating Force: 12 lbf (maintain motion), 9 lbf (latches)

Our products are tested to the standards of and certified by the American Architectural Manufacturer's Association, the National Fenestration Rating Council and the Window & Door Manufacturers Association.



**QUAKER**  
COMMERCIAL WINDOWS AND DOORS

## ARCHITECTURAL PAINT COATINGS AND FINISHES

◇ Baked on powder coat finish meets ANSA/AAMA 2604 specs and is available in unlimited colors

- 11 Popular Colors

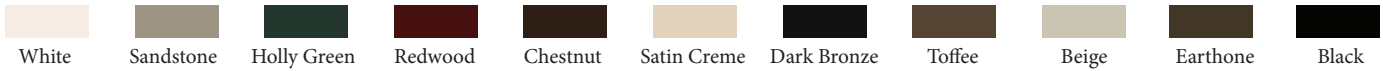

- 19 Impressive Colors

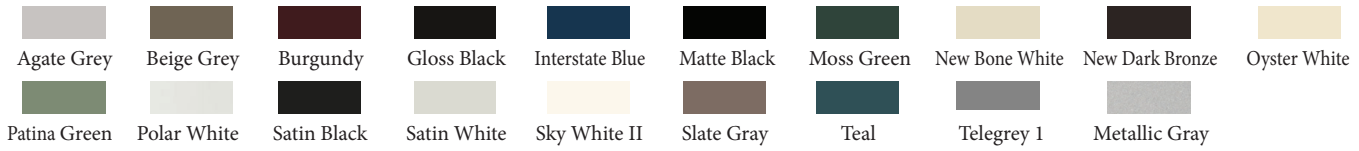

- 7 Resemble Colors (painted finish resembling anodized)



- Unlimited Custom Colors

\* Printed colors shown here may not accurately depict actual painted colors. Color samples are available upon request.

◇ ANSA/AAMA 2605 powder coat finishes

◇ AAMA 611-98 Class I clear and tinted anodized finishes

Our products are tested to the standards of and certified by the American Architectural Manufacturer's Association, the National Fenestration Rating Council and the Window & Door Manufacturers Association.



**QUAKER**  
COMMERCIAL WINDOWS AND DOORS



**QUAKER**  
COMMERCIAL WINDOWS AND DOORS

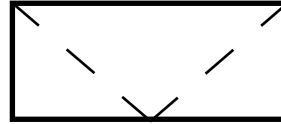

Traditional  
SERIES

**T600 Series  
AW-PG70  
3 1/4" Frame Depth  
Hopper (Project-in)**

# T600 HOPPER

This document contains confidential and proprietary information intended for the private use of Quaker.  
© 2016 Quaker Window Products Co., INC. All rights reserved.  
Quaker reserves the right to change any/all designs without notice. Due to periodic re-certification requirements, result shown may vary.

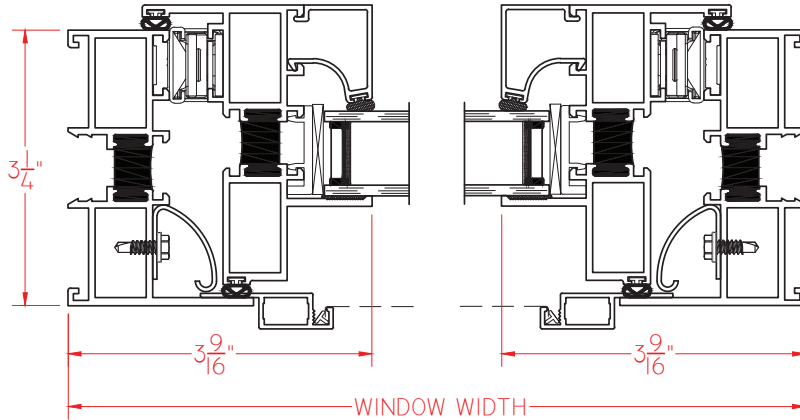

① HORIZONTAL  
CROSS SECTION

Ⓐ VERTICAL  
CROSS SECTION

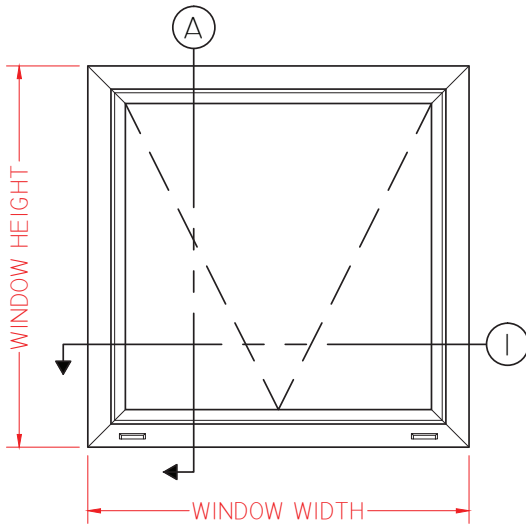

ELEVATION SCALE 3/4" = 1'-0"

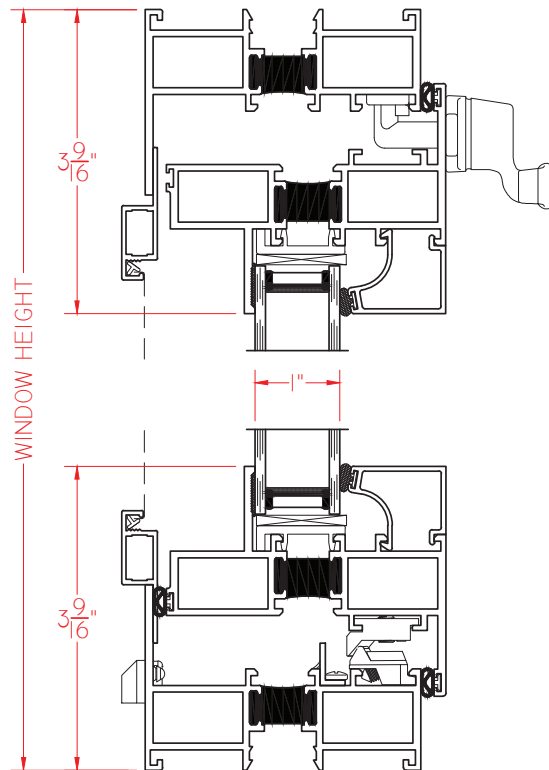

SCALE 1:2

Our products are tested to the standards of and certified by the American Architectural Manufacturer's Association, the National Fenestration Rating Council and the Window & Door Manufacturers Association.



**QUAKER**  
COMMERCIAL WINDOWS AND DOORS



**QUAKER**  
COMMERCIAL WINDOWS AND DOORS

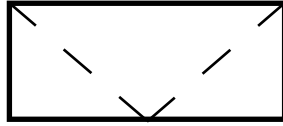

Traditional  
SERIES

**T600 Series  
AW-PG70  
3 1/4" Frame Depth  
Hopper (Project-in)**

**T600 FIXED/HOPPER**

This document contains confidential and proprietary information intended for the private use of Quaker.  
© 2016 Quaker Window Products Co., INC. All rights reserved.  
Quaker reserves the right to change any/all designs without notice. Due to periodic re-certification requirements, result shown may vary.

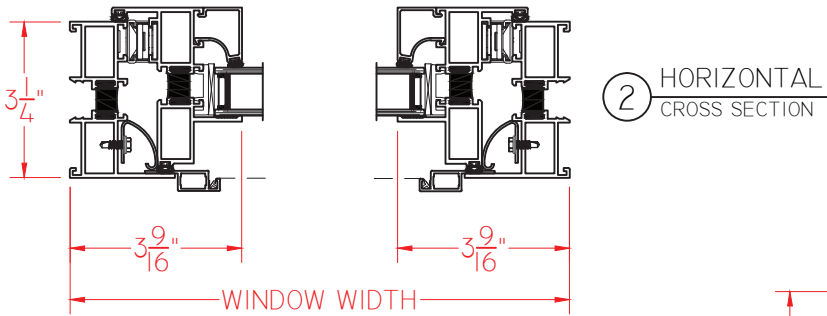
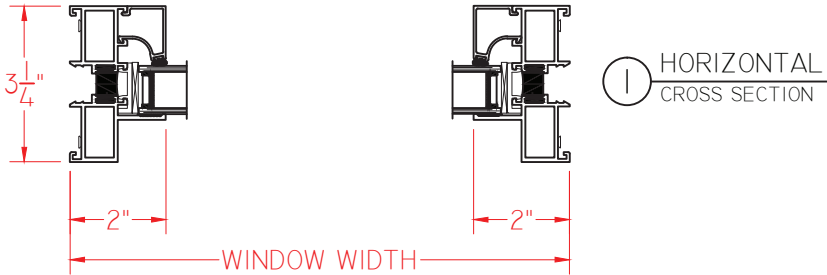

Ⓐ VERTICAL CROSS SECTION

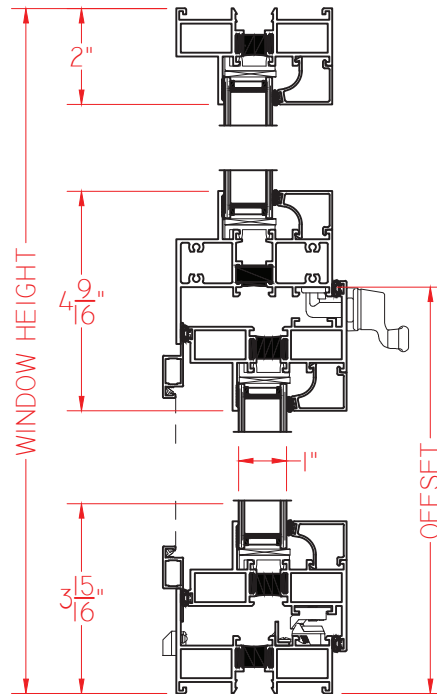
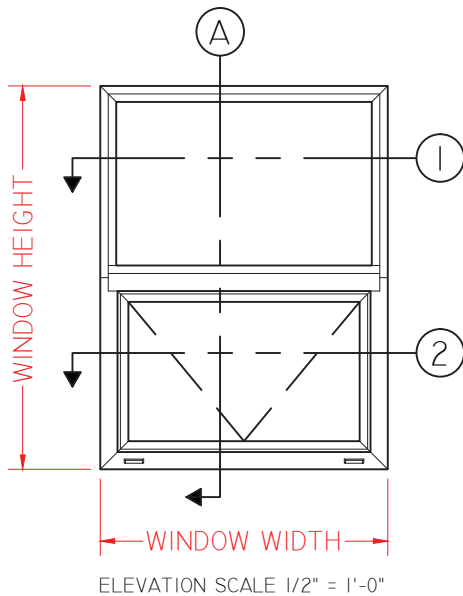

SCALE 1:4

Our products are tested to the standards of and certified by the American Architectural Manufacturer's Association, the National Fenestration Rating Council and the Window & Door Manufacturers Association.



**QUAKER**  
COMMERCIAL WINDOWS AND DOORS