

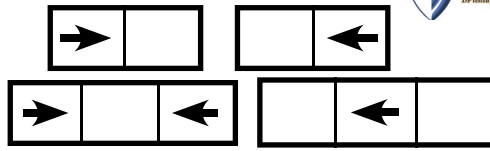

QUAKER
COMMERCIAL WINDOWS AND DOORS



Crusader Series
R-DP50
3 1/4" Frame Depth
Horizontal Slider



CRUSADER SERIES HORIZONTAL SLIDER

The Quaker Crusader Series Horizontal Slider window is ideal for a variety of applications including - Energy Efficient, Apartments, Assisted Living and Housing Authority.

FEATURES

- ◇ **Commercial Framing System**
 - 3 1/4" main frame
 - 0.060" wall thickness of frame, 0.055" wall thickness of sash
- ◇ **Enhanced Design**
 - Mitered and welded corners
- ◇ **Glazing**
 - 3/4" insulated glass
- ◇ **Hardware**
 - Brass rollers with stainless steel axle pins for easy operation
- ◇ **Screen**
 - Extruded aluminum screen frame with BetterVue™ mesh

OPTIONS

- ◇ **Available Configurations**
 - Fixed-Active
 - Active-Fixed
 - Active-Fixed-Active
 - Fixed-Active-Fixed
- ◇ **Muntin Choices**
 - Internal or simulated divided lites available
- ◇ **Limited Travel Hardware**
- ◇ **Nailing Fin**
- ◇ **Screen**
 - Extruded aluminum screen frame with aluminum wire mesh
 - Extruded aluminum screen frame with sunscreen mesh
 - Extruded aluminum screen frame with stainless steel 0.009" thickness mesh
- ◇ **Glazing**
 - Capillary tubes
 - Argon gas
 - Wide variety of glazing, tinting and thickness options
- ◇ **Panning & Trim Choices**
 - Wide variety of panning, receptor and trim available
- ◇ **Mulling**
 - Wide variety of structural mulls

BENEFITS

- ◇ The capacity to match exterior colors for unique project facades
- ◇ The ability to facilitate large sizes for taller and wider window openings

PERFORMANCE

- ◇ Structural & Thermal (test reports or thermal simulations available upon request)

Model	Slider
AAMA/WDMA/CSA 101/I.S.2/A440-08 Rating	R-PG50
Structural Load P.S.F.	75.19
Air at 50 MPH (cfm/ft ²)	0.01
Water (No Penetration) P.S.F.	7.52
U-Value (with Low-E and Argon)	0.24-0.29
SHGC (with Low-E and Argon)	0.14-0.33

Window test size: 63" x 44"
Operating Force: 24 lbf (Initiate motion), 7 lbf (Maintain motion), 1 lbf (Locks)

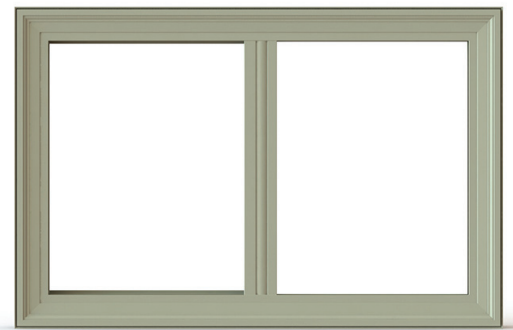

Our products are tested to the standards of and certified by the American Architectural Manufacturer's Association, the National Fenestration Rating Council and the Window & Door Manufacturers Association.



QUAKER
COMMERCIAL WINDOWS AND DOORS

VINYL COLORS AND ARCHITECTURAL EXTERIOR PAINT COATINGS AND FINISHES

◇ Solid Vinyl Colors (interior & exterior)



White



Sandstone



Beige

◇ Optional Faux Wood Grain (interior only)



Dark Oak (available with white or painted exterior only)

◇ Optional Painted Colors (exterior only)



Holly Green



Redwood



Chestnut



Satin Creme



Dark Bronze



Toffee



Earthone



Black



White



Sandston



Beige

◇ Optional Unlimited Custom Painted Colors (exterior only)



* Printed colors shown here may not accurately depict actual vinyl or painted colors. Color samples are available upon request.

Our products are tested to the standards of and certified by the American Architectural Manufacturer's Association, the National Fenestration Rating Council and the Window & Door Manufacturers Association.



QUAKER
COMMERCIAL WINDOWS AND DOORS



QUAKER
COMMERCIAL WINDOWS AND DOORS



Crusader Series
R-DP50
3 1/4" Frame Depth
Horizontal Slider

CRUSADER SL

This document contains confidential and proprietary information intended for the private use of Quaker.
© 2016 Quaker Window Products Co., INC. All rights reserved.
Quaker reserves the right to change any/all designs without notice. Due to periodic re-certification requirements, result shown may vary.

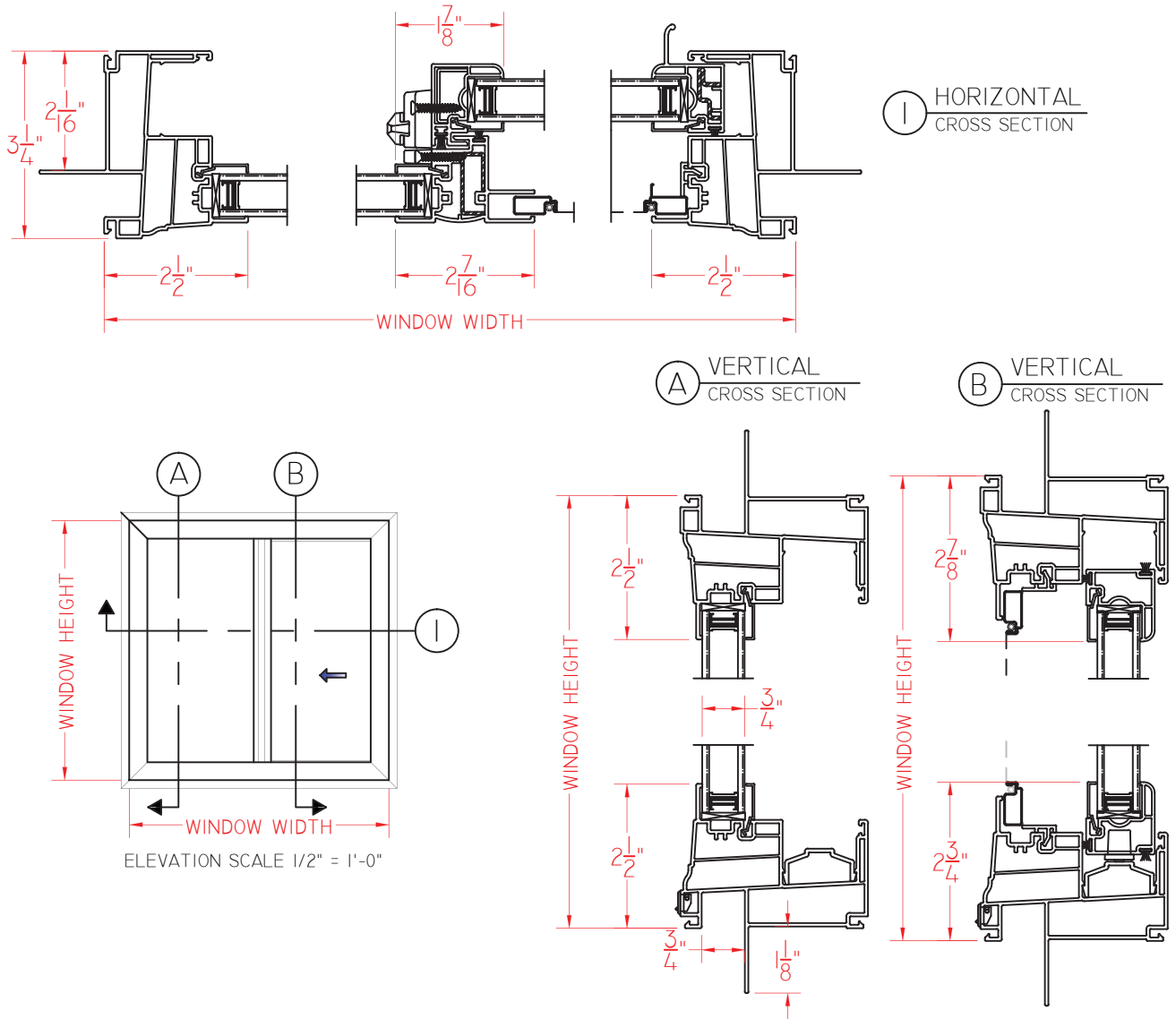

CRUSADER HORIZONTAL SLIDER 02.05.2015 VERSION 1.0

SCALE 1:3

Our products are tested to the standards of and certified by the American Architectural Manufacturer's Association, the National Fenestration Rating Council and the Window & Door Manufacturers Association.



QUAKER
COMMERCIAL WINDOWS AND DOORS



QUAKER
COMMERCIAL WINDOWS AND DOORS

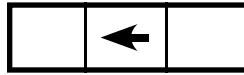

Crusader Series
R-DP50
3 1/4" Frame Depth
Horizontal Slider

CRUSADER CENTER VENT SLIDER

This document contains confidential and proprietary information intended for the private use of Quaker.
© 2016 Quaker Window Products Co., INC. All rights reserved.
Quaker reserves the right to change any/all designs without notice. Due to periodic re-certification requirements, result shown may vary.

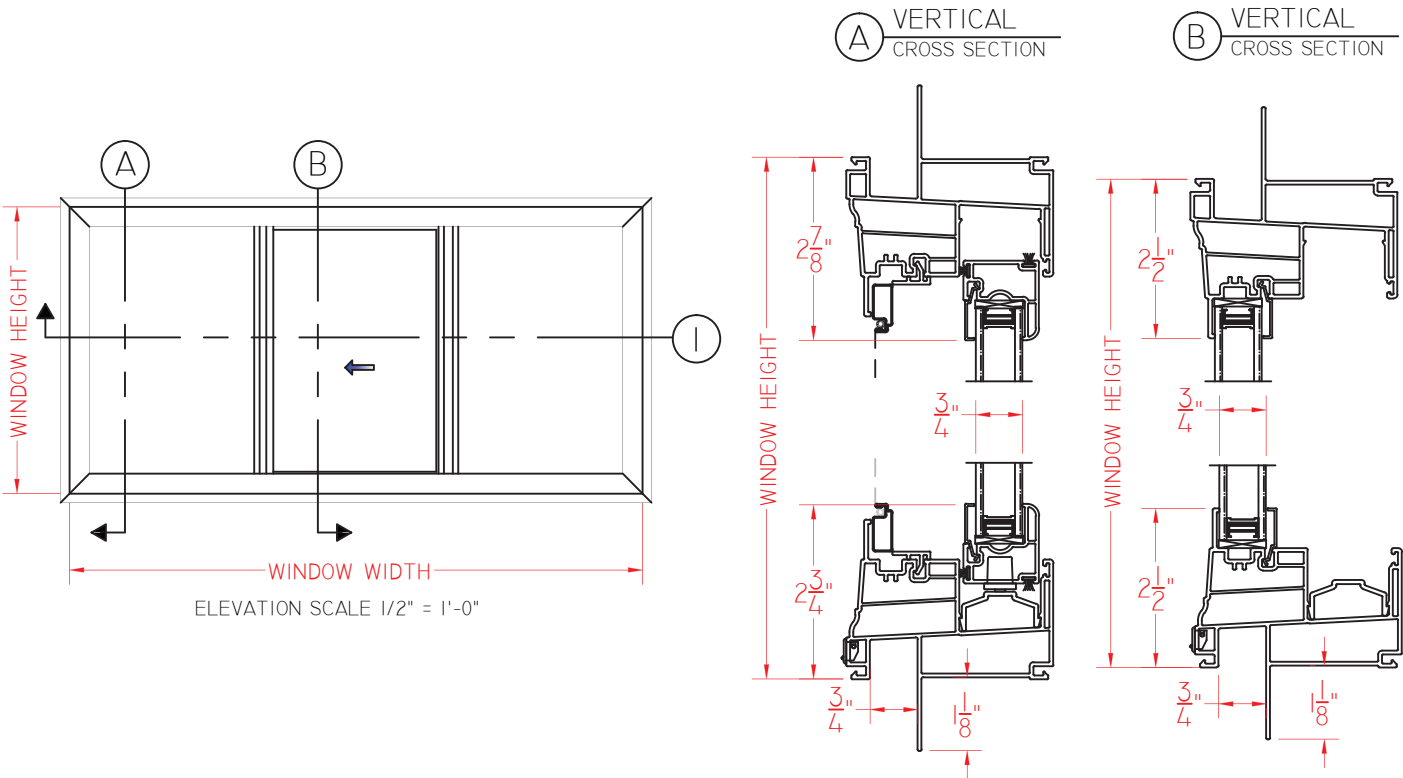
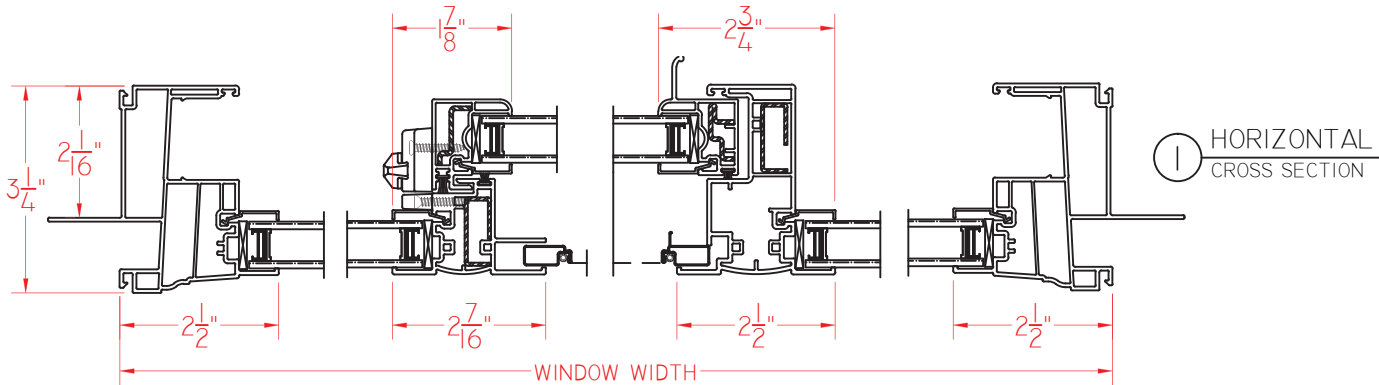

CRUSADER CENTER VENT SLIDER 02.05.2015 VERSION 1.0

SCALE 1:3

Our products are tested to the standards of and certified by the American Architectural Manufacturer's Association, the National Fenestration Rating Council and the Window & Door Manufacturers Association.



QUAKER
COMMERCIAL WINDOWS AND DOORS



QUAKER
COMMERCIAL WINDOWS AND DOORS



Crusader Series
R-DP50
3 1/4" Frame Depth
Horizontal Slider

CRUSADER END VENT SLIDER

This document contains confidential and proprietary information intended for the private use of Quaker.
© 2016 Quaker Window Products Co., INC. All rights reserved.
Quaker reserves the right to change any/all designs without notice. Due to periodic re-certification requirements, result shown may vary.

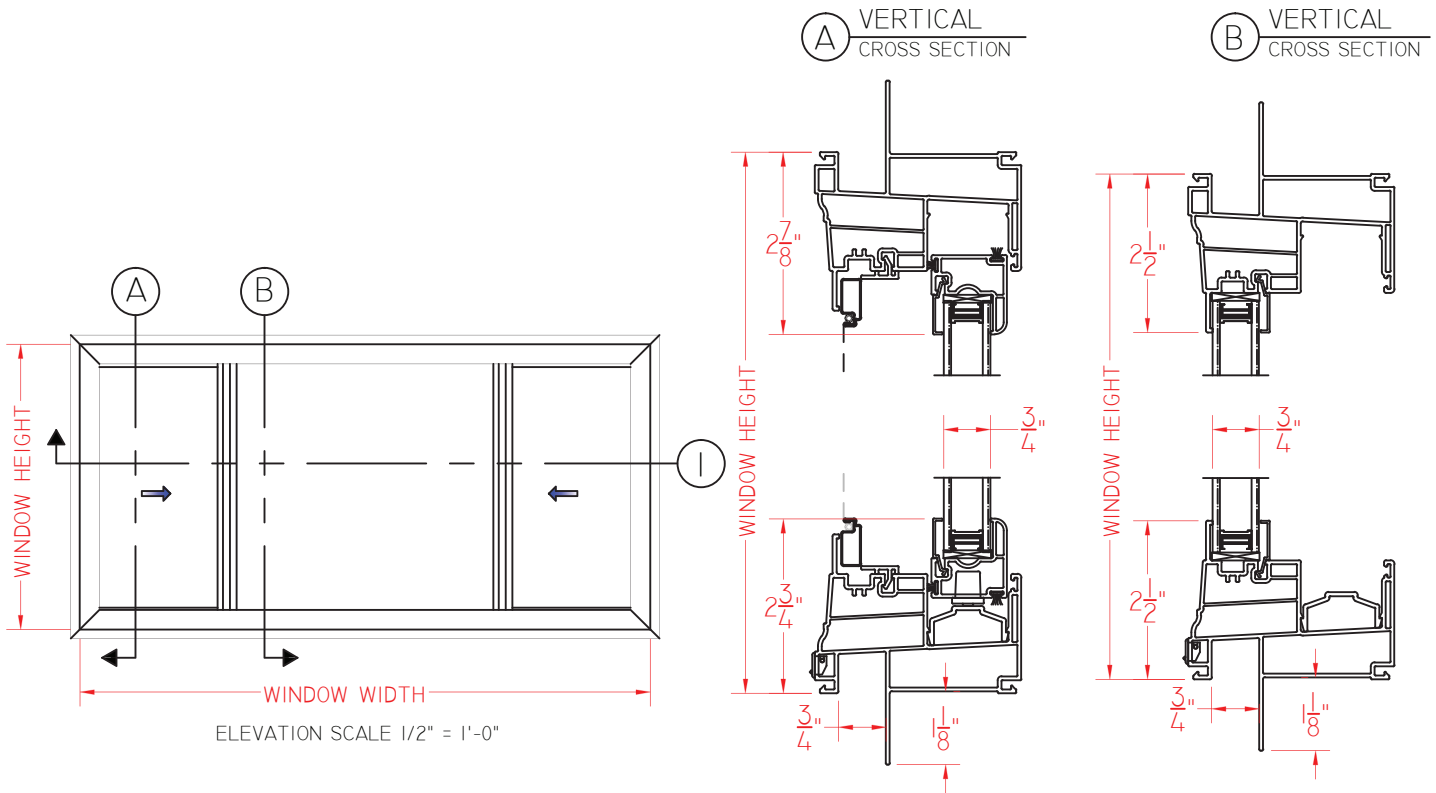
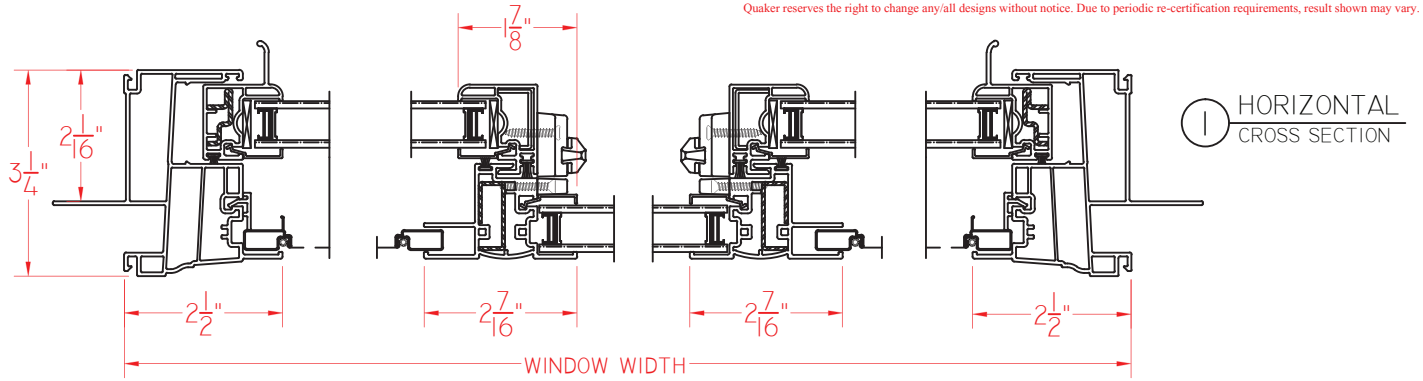

CRUSADER END VENT SLIDER 02.05.2015 VERSION 1.0

SCALE 1:3

Our products are tested to the standards of and certified by the American Architectural Manufacturer's Association, the National Fenestration Rating Council and the Window & Door Manufacturers Association.



QUAKER
COMMERCIAL WINDOWS AND DOORS