

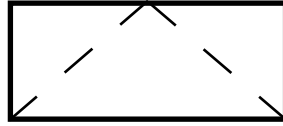

**QUAKER**  
COMMERCIAL WINDOWS AND DOORS



Manchester  
SERIES

**Manchester Series**  
**R-40**  
**3 1/4" Frame Depth**  
**Awning (Project-Out)**

## MANCHESTER SERIES AWNING (PROJECT-OUT)

The Quaker Manchester Series Awning window is ideal for a variety of applications including - Energy Efficient, Apartments, Assisted Living and Housing Authority.

### FEATURES

- ◇ **Commercial Framing System**
  - 3 1/4" main frame
- ◇ **Enhanced Design**
  - Mitered and welded corners
- ◇ **Glazing**
  - 3/4" insulated glass
- ◇ **Hardware**
  - Single point locking system with fold-down handle to avoid interference with window blinds
- ◇ **Screen**
  - Extruded aluminum screen frame with BetterVue™ mesh

### BENEFITS

- ◇ The capacity to match exterior colors for unique project facades
- ◇ The ability to facilitate large sizes for taller and wider window openings

### OPTIONS

- ◇ **Available Configurations**
  - Project-out awning
- ◇ **Muntin Choices**
  - Internal or simulated divided lites available
- ◇ **Limited travel hardware**
- ◇ **Nailing Fin**
- ◇ **Screen**
  - Extruded aluminum screen frame with aluminum wire mesh
  - Extruded aluminum screen frame with sunscreen mesh
  - Extruded aluminum screen frame with stainless steel 0.009" thickness mesh
- ◇ **Glazing**
  - Capillary tubes
  - Argon gas
- ◇ **Panning & Trim Choices**
  - Wide variety of panning, receptor and trim available
- ◇ **Mulling**
  - Wide variety of structural mulls

### PERFORMANCE

- ◇ Structural & Thermal (test reports or thermal simulations available upon request)

Model	Awning (Project-Out)
AAMA/WDMA/CSA 101/I.S.2/A440-08 Rating	R-40
Structural Load P.S.F.	60.15
Air at 50 MPH (cfm/ft <sup>2</sup> )	0.03
Water (No Penetration) P.S.F.	6.06
U-Value (with Low-E and Argon)	0.23-0.27
SHGC (with Low-E and Argon)	0.12-0.28

Window test size: 48" x 18"  
Operating Force: 3.5 lbf (maintain motion), 1 lbf (locks)



Our products are tested to the standards of and certified by the American Architectural Manufacturer's Association, the National Fenestration Rating Council and the Window & Door Manufacturers Association.



**QUAKER**  
COMMERCIAL WINDOWS AND DOORS

# VINYL COLORS AND ARCHITECTURAL EXTERIOR PAINT COATINGS AND FINISHES

## ◇ Solid Vinyl Colors (interior & exterior)



White



Sandstone



Beige

## ◇ Optional Faux Wood Grain (interior only)



Dark Oak (available with white or painted exterior only)

## ◇ Optional Painted Colors (exterior only)



Holly Green



Redwood



Chestnut



Satin Creme



Dark Bronze



Toffee



Earthone



Black



White



Sandston



Beige

## ◇ Optional Unlimited Custom Painted Colors (exterior only)



\* Printed colors shown here may not accurately depict actual vinyl or painted colors. Color samples are available upon request.

Our products are tested to the standards of and certified by the American Architectural Manufacturer's Association, the National Fenestration Rating Council and the Window & Door Manufacturers Association.



**QUAKER**  
COMMERCIAL WINDOWS AND DOORS



**QUAKER**  
COMMERCIAL WINDOWS AND DOORS

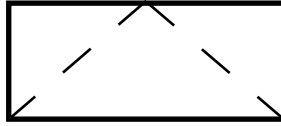

**Manchester**  
SERIES

**Manchester Series**  
**R-DP50**  
**3 1/4" Frame Depth**  
**Awning (Project-Out)**

**MANCHESTER AWN**

This document contains confidential and proprietary information intended for the private use of Quaker.  
© 2016 Quaker Window Products Co., INC. All rights reserved.  
Quaker reserves the right to change any/all designs without notice. Due to periodic re-certification requirements, result shown may vary.

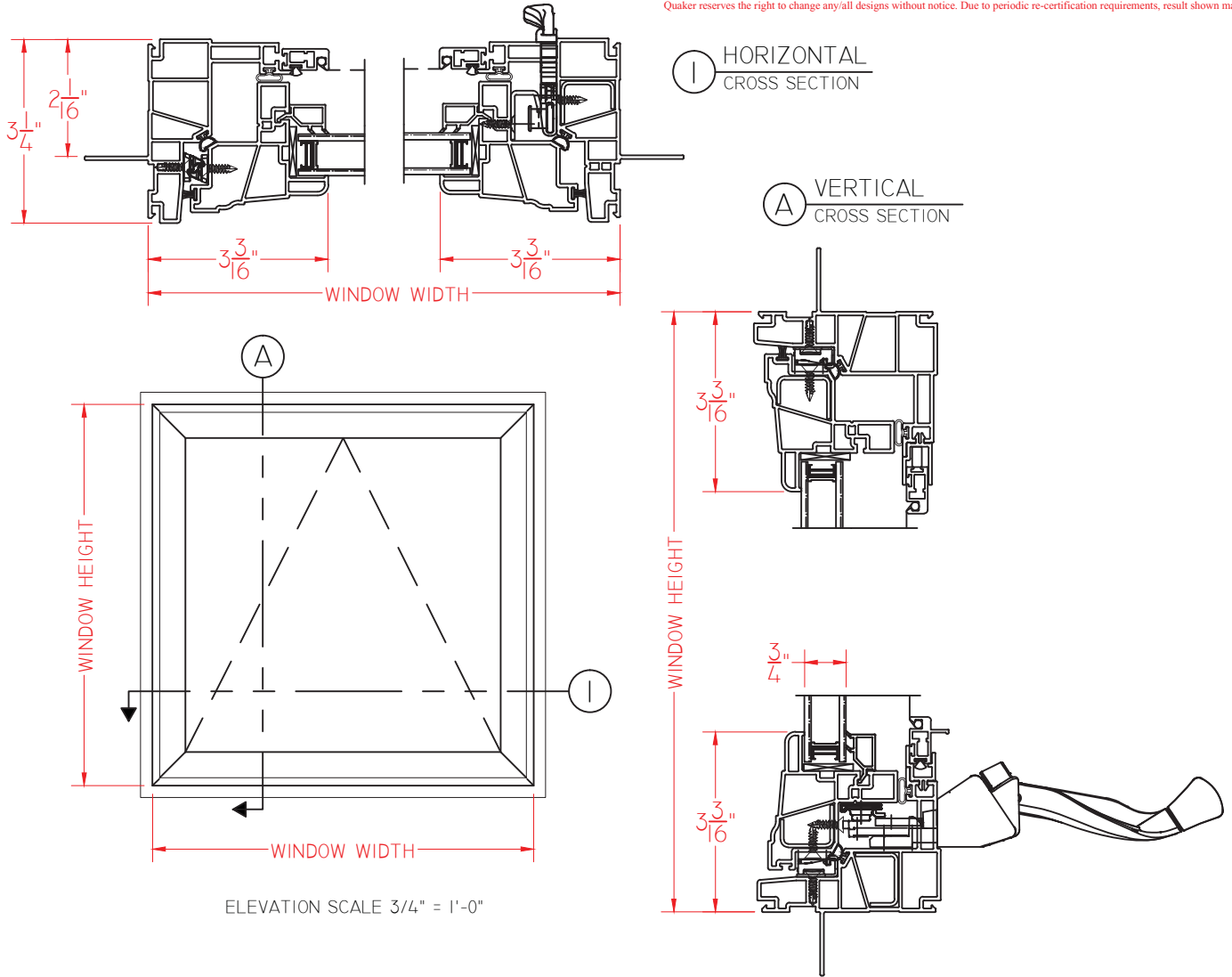

MANCHESTER AWNING 12.17.2015 VERSION 2.0

SCALE 1:3

Our products are tested to the standards of and certified by the American Architectural Manufacturer's Association, the National Fenestration Rating Council and the Window & Door Manufacturers Association.



**QUAKER**  
COMMERCIAL WINDOWS AND DOORS