

**V300 Series
CW-50
3 1/4" Frame Depth
Picture Window (Fixed)**

V300 SERIES PICTURE WINDOW (FIXED)

The Quaker V300 Series Picture window is ideal for a variety of applications including - Energy Efficient, Apartments, Assisted Living and Housing Authority.

FEATURES

- ◇ **Commercial Framing System**
 - 3 1/4" main frame
- ◇ **Enhanced Design**
 - Mitered and welded corners
- ◇ **Glazing**
 - 1" insulated glass
- ◇ **Integral Nailing Fin**

OPTIONS

- ◇ **Available Configurations**
 - Fixed
- ◇ **Muntin Choices**
 - Internal or simulated divided lites available
- ◇ **Glazing**
 - Capillary tubes
 - Argon gas
- ◇ **Panning & Trim Choices**
 - Wide variety of panning, receptor and trim available
- ◇ **Mulling**
 - Wide variety of structural mulls

BENEFITS

- ◇ The capacity to match exterior colors for unique project facades
- ◇ The ability to facilitate large sizes for taller and wider window openings

PERFORMANCE

- ◇ Structural & Thermal (test reports or thermal simulations available upon request)

Model	Picture Window (Fixed)
AAMA/WDMA/CSA 101/I.S.2/A440-08 Rating	CW-50
Structural Load P.S.F.	75.19
Air at 50 MPH (cfm/ft ²)	0.01
Water (No Penetration) P.S.F.	7.5
U-Value (with Low-E and Argon)	0.21-0.27
SHGC (with Low-E and Argon)	0.15-0.35

Window test size: 78" x 78"

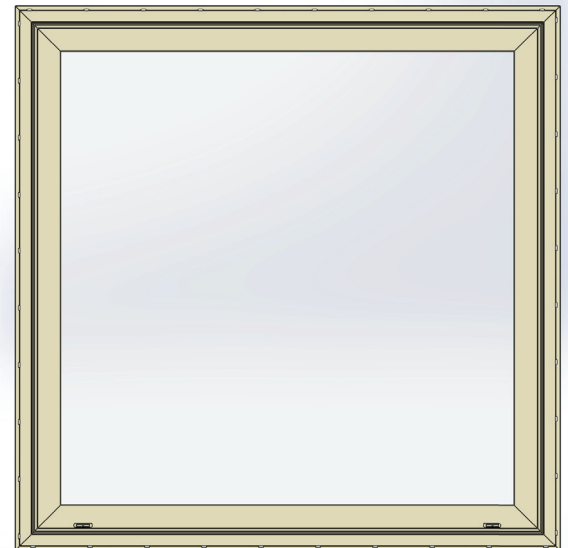

Our products are tested to the standards of and certified by the American Architectural Manufacturer's Association, the National Fenestration Rating Council and the Window & Door Manufacturers Association.



QUAKER
COMMERCIAL WINDOWS AND DOORS

VINYL COLORS AND ARCHITECTURAL EXTERIOR PAINT COATINGS AND FINISHES

◇ Solid Vinyl Colors (interior & exterior)



White



Sandstone



Beige

◇ Optional Painted Colors (exterior only)



Holly Green



Redwood



Chestnut



Satin Creme



Dark Bronze



Toffee



Earthone



Black



White



Sandston



Beige

◇ Optional Unlimited Custom Painted Colors (exterior only)



* Printed colors shown here may not accurately depict actual vinyl or painted colors. Color samples are available upon request.

Our products are tested to the standards of and certified by the American Architectural Manufacturer's Association, the National Fenestration Rating Council and the Window & Door Manufacturers Association.



QUAKER
COMMERCIAL WINDOWS AND DOORS



QUAKER
COMMERCIAL WINDOWS AND DOORS

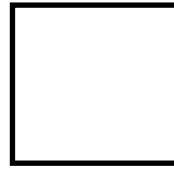

**V300 Series
CW-50
3 1/4" Frame Depth
Picture Window (Fixed)**

V300 FIXED

This document contains confidential and proprietary information intended for the private use of Quaker.
© 2016 Quaker Window Products Co., INC. All rights reserved.
Quaker reserves the right to change any/all designs without notice. Due to periodic re-certification requirements, result shown may vary.

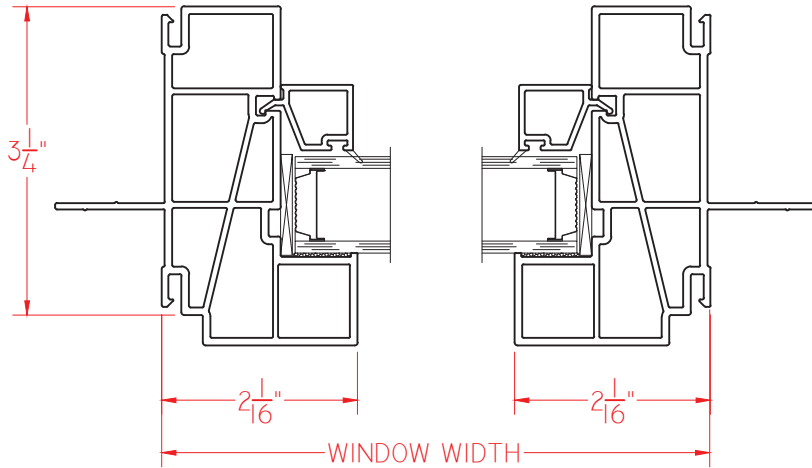

① HORIZONTAL CROSS SECTION

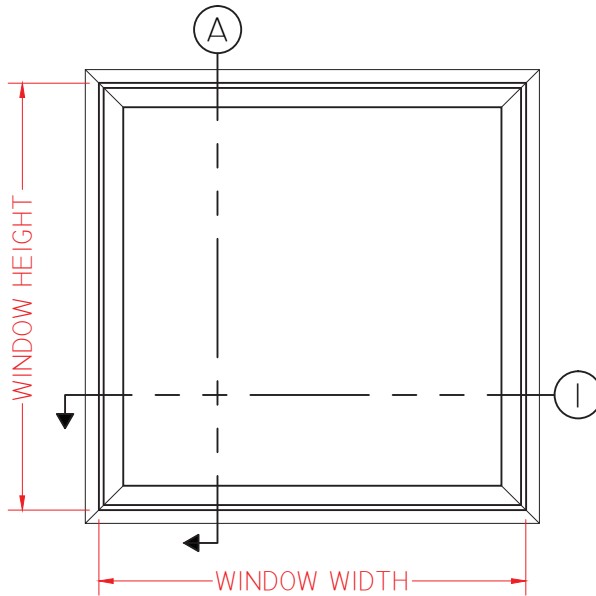

ELEVATION SCALE 3/4" = 1'-0"

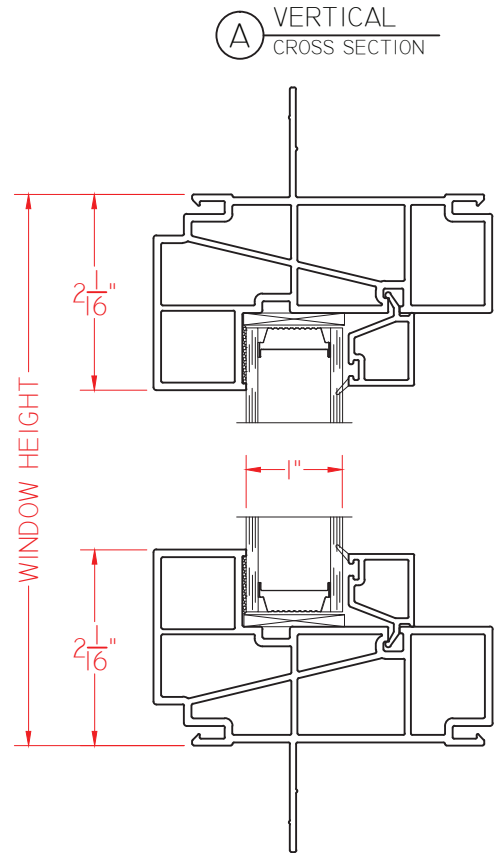

Ⓐ VERTICAL CROSS SECTION

V300 FIXED 01.21.2016 VERSION 1

SCALE 1:2

Our products are tested to the standards of and certified by the American Architectural Manufacturer's Association, the National Fenestration Rating Council and the Window & Door Manufacturers Association.



QUAKER
COMMERCIAL WINDOWS AND DOORS