

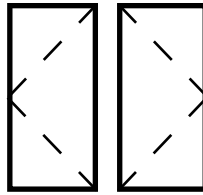

QUAKER
COMMERCIAL WINDOWS AND DOORS



BRIGHTON
SERIES

**Brighton Series
LC-60
6" Frame Depth
Casement**

BRIGHTON SERIES CASEMENT

The Quaker Brighton Series Casement window is ideal for a variety of applications including - Energy Efficient, Apartments, Assisted Living and Housing Authority.

FEATURES

- ◇ **Commercial Framing System**
 - 6" main frame
- ◇ **Enhanced Design**
 - Extruded clad exterior, pine interior
- ◇ **Glazing**
 - ¾" insulated glass
- ◇ **Hardware**
 - Multi-point locking system with single latch
- ◇ **Screen**
 - Extruded aluminum screen frame with BetterVue™ mesh

OPTIONS

- ◇ **Available Configurations**
 - Project-out casement
- ◇ **Muntin Choices**
 - Internal or simulated divided lites available
- ◇ **Hardware**
 - Egress hardware
 - Limited travel hardware
- ◇ **Nailing Fin**
- ◇ **Screen**
 - Extruded aluminum screen frame with aluminum wire mesh
 - Extruded aluminum screen frame with sunscreen mesh
 - Extruded aluminum screen frame with stainless steel 0.009" thickness mesh
- ◇ **Glazing**
 - Capillary tubes
 - Argon gas
 - Wide variety of glazing, tinting and thickness options
- ◇ **Panning & Trim Choices**
 - Wide variety of panning, receptor and trim available
- ◇ **Mulling**
 - Wide variety of structural mulls

BENEFITS

- ◇ The capacity to match exterior colors for unique project facades
- ◇ The ability to facilitate large sizes for taller and wider window openings

PERFORMANCE

- ◇ Structural & Thermal (test reports or thermal simulations available upon request)

Model	Casement
AAMA/WDMA/CSA 101/I.S.2/A440-08 Rating	LC-60
Structural Load P.S.F.	90.23
Air at 50 MPH (cfm/ft ²)	<0.01
Water (No Penetration) P.S.F.	9.19
U-Value (with Low-E and Argon)	0.28-0.32
SHGC (with Low-E and Argon)	0.12-0.28

Window test size: 36" × 72"
Operating Force: 2 lbf (Initiate motion), 1 lbf (Latches)

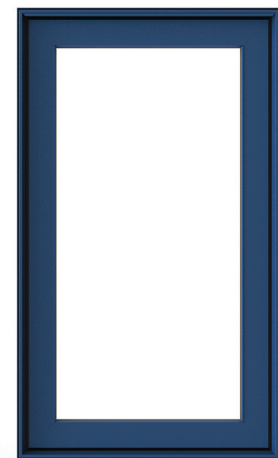

Our products are tested to the standards of and certified by the American Architectural Manufacturer's Association, the National Fenestration Rating Council and the Window & Door Manufacturers Association.



QUAKER
COMMERCIAL WINDOWS AND DOORS

ARCHITECTURAL PAINT COATINGS AND FINISHES

◇ Baked on powder coat finish meets ANSA/AAMA 2604 specs and is available in unlimited colors

- 11 Popular Colors

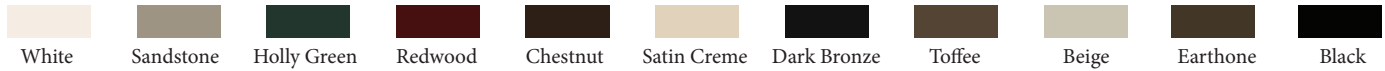

- 19 Impressive Colors

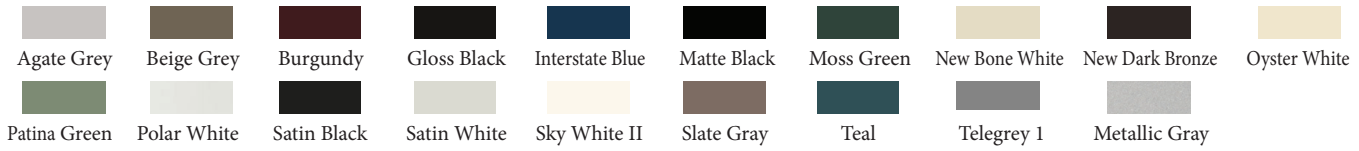

- 7 Resemble Colors (painted finish resembling anodized)



- Unlimited Custom Colors

* Printed colors shown here may not accurately depict actual painted colors. Color samples are available upon request.

◇ ANSA/AAMA 2605 powder coat finishes

◇ AAMA 611-98 Class I clear and tinted anodized finishes

Our products are tested to the standards of and certified by the American Architectural Manufacturer's Association, the National Fenestration Rating Council and the Window & Door Manufacturers Association.



QUAKER
COMMERCIAL WINDOWS AND DOORS



QUAKER
COMMERCIAL WINDOWS AND DOORS

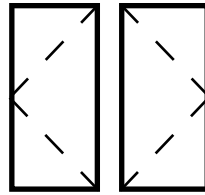

BRIGHTON
SERIES

Brighton Series
LC-60
6" Frame Depth
Casement

BRIGHTON CA

This document contains confidential and proprietary information intended for the private use of Quaker.
© 2016 Quaker Window Products Co., INC. All rights reserved.
Quaker reserves the right to change any/all designs without notice. Due to periodic re-certification requirements, result shown may vary.

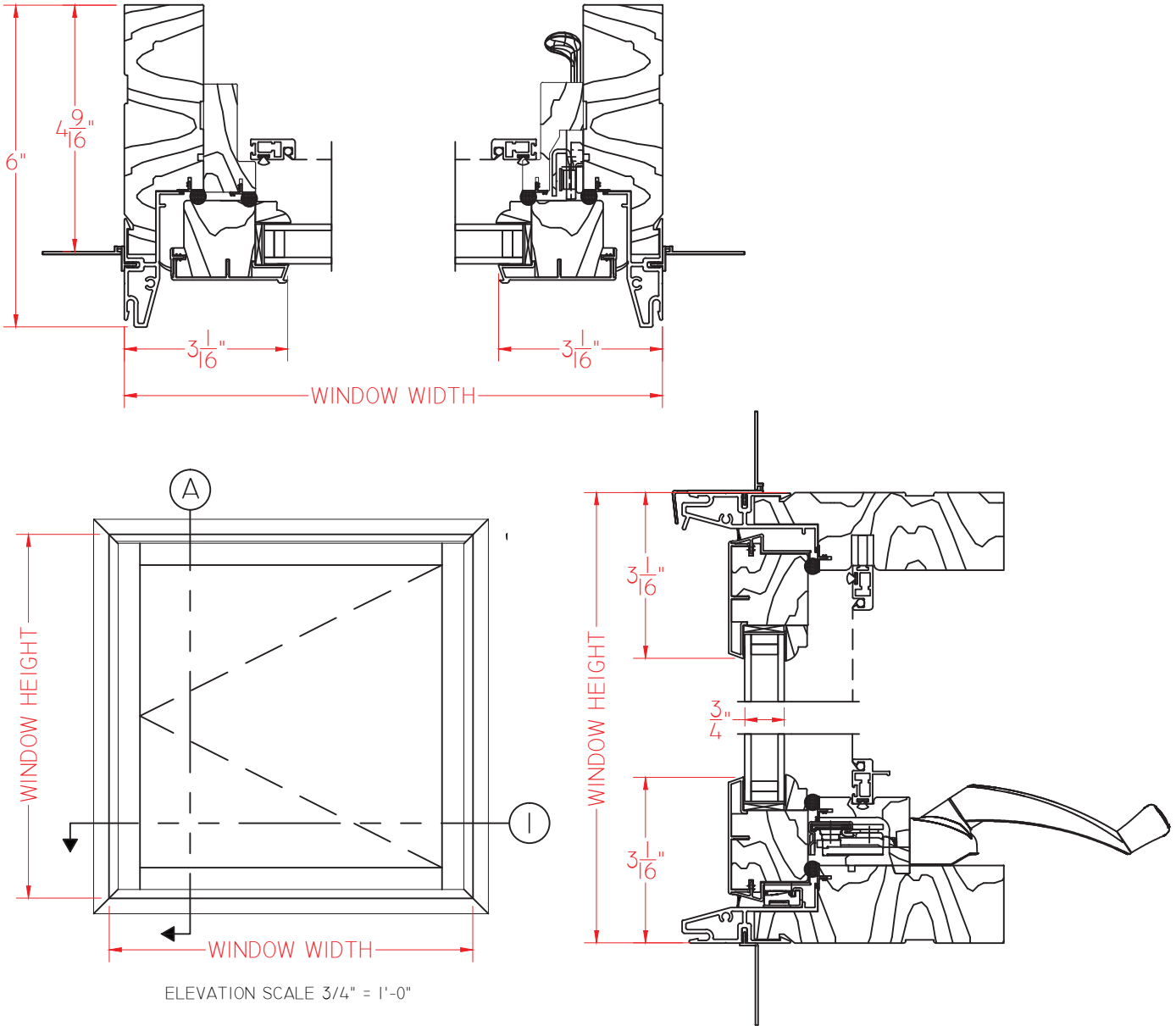

BRIGHTON CASEMENT 12-29-2015 VERSION 3.0

SCALE 1:3

Our products are tested to the standards of and certified by the American Architectural Manufacturer's Association, the National Fenestration Rating Council and the Window & Door Manufacturers Association.



QUAKER
COMMERCIAL WINDOWS AND DOORS