



**Brighton
R-50**

**5 15/16" Frame Depth
Hinged Door (Inswing)**

BRIGHTON SERIES HINGED DOOR (INSWING)

The Quaker Brighton Series Hinged Inswing door is ideal for a variety of applications including - Energy Efficient, Apartments and Assisted Living.

FEATURES

- ◇ **Commercial Framing System**
 - 5 15/16' main frame
- ◇ **Enhanced Design**
 - Solid extruded aluminum clad exterior framing: 0.078" metal thickness
 - Radiatta pine interior
 - 8 1/2" bottom rail height
 - Bronze anodized aluminum sill
 - Adjustable nailing fin to fit frame depths ranging from 4 9/16" to 5 5/16"
- ◇ **Glazing**
 - 3/4" insulated glass
 - Low-E with argon gas
- ◇ **Hardware**
 - 3 Heavy-duty, adjustable hinges
 - Multi-point hardware
 - Munchen or New Orleans style handle from Hoppe
- ◇ **Screen**
 - Extruded aluminum screen frame with BetterVue™ mesh

BENEFITS

- ◇ The capacity to match exterior colors for unique project facades
- ◇ The capacity to match interior colors for unique decor
- ◇ The ability to facilitate custom sizes for taller and wider door openings

PERFORMANCE

- ◇ Structural & Thermal (test reports or thermal simulations available upon request)

Model	Brighton Hinged Inswing Door
AAMA/WDMA/CSA 101/IS.2/A440-08 Rating	R-40, LC-50
Structural Load P.S.F.	
Air at 50 MPH (cfm/ft ²)	
Water (No Penetration) P.S.F.	
U-Value (with EnergyMax Glass Package)	0.28
SHGC (with EnergyMax Glass Package)	0.15
Test size	

Our products are tested to the standards of and certified by the American Architectural Manufacturer's Association, the National Fenestration Rating Council and the Window & Door Manufacturers Association.



OPTIONS

- ◇ **Available Configurations**
 - Single Panel Active
 - Fixed-Active, Active-Fixed or Fixed-Fixed
 - Inactive-Active or Active-Inactive (French)
 - Active-Fixed-Fixed, Fixed-Active-Fixed, Fixed-Fixed-Active or Fixed-Fixed-Fixed
 - Sidelites
 - Transoms
- ◇ **Muntin Choices**
 - Internal, wood removable or simulated divided lites available
- ◇ **Panels**
 - 1/4 or 1/2 Panel with 0, 1 or 2 simulated raised plots
 - 10" bottom rail height
- ◇ **Sill**
 - ADA option
 - Mill finish
- ◇ **Screen**
 - Extruded aluminum screen frame w/alum. wire mesh
 - Extruded aluminum screen frame with sunscreen mesh
 - Extruded aluminum screen frame with stainless steel 0.009" thickness mesh
 - Multiple retractable screen systems
- ◇ **Glazing**
 - Capillary tubes
 - Wide variety of glazing, tinting and thickness options
- ◇ **Panning & Trim Choices**
 - Wide variety of trim available
- ◇ **Mulling**
 - Wide variety of structural mulls

ARCHITECTURAL PAINT COATINGS AND FINISHES

◇ Baked on powder coat finish meets ANSA/AAMA 2604 specs and is available in unlimited colors

- 11 Popular Colors

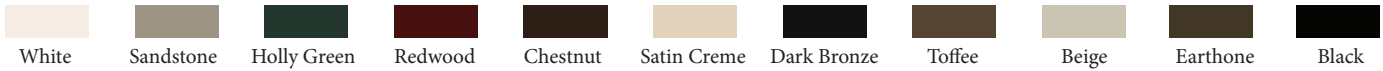

- 19 Impressive Colors

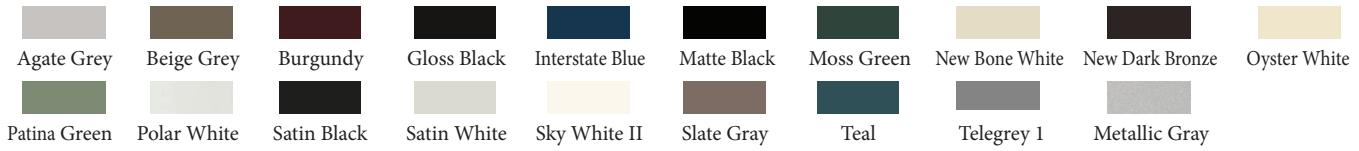

- 7 Resemble Colors (painted finish resembling anodized)



- Unlimited Custom Colors

◇ ANSA/AAMA 2605 powder coat finishes

◇ AAMA 611-98 Class I clear and tinted anodized finishes

INTERIOR FINISHES

◇ Interior painted finish is available in Natural Pine, Pre-Primed or Pre-Finished in white or any other colors



* Printed colors shown here may not accurately depict actual painted colors. Color samples are available upon request.

Our products are tested to the standards of and certified by the American Architectural Manufacturer's Association, the National Fenestration Rating Council and the Window & Door Manufacturers Association.





QUAKER
COMMERCIAL WINDOWS AND DOORS



**Brighton
R-50**

**5 15/16" Frame Depth
Hinged Door (Inswing)**

BRIGHTON SERIES HINGED DOOR (INSWING)

SCALE: 3" = 1'-0"

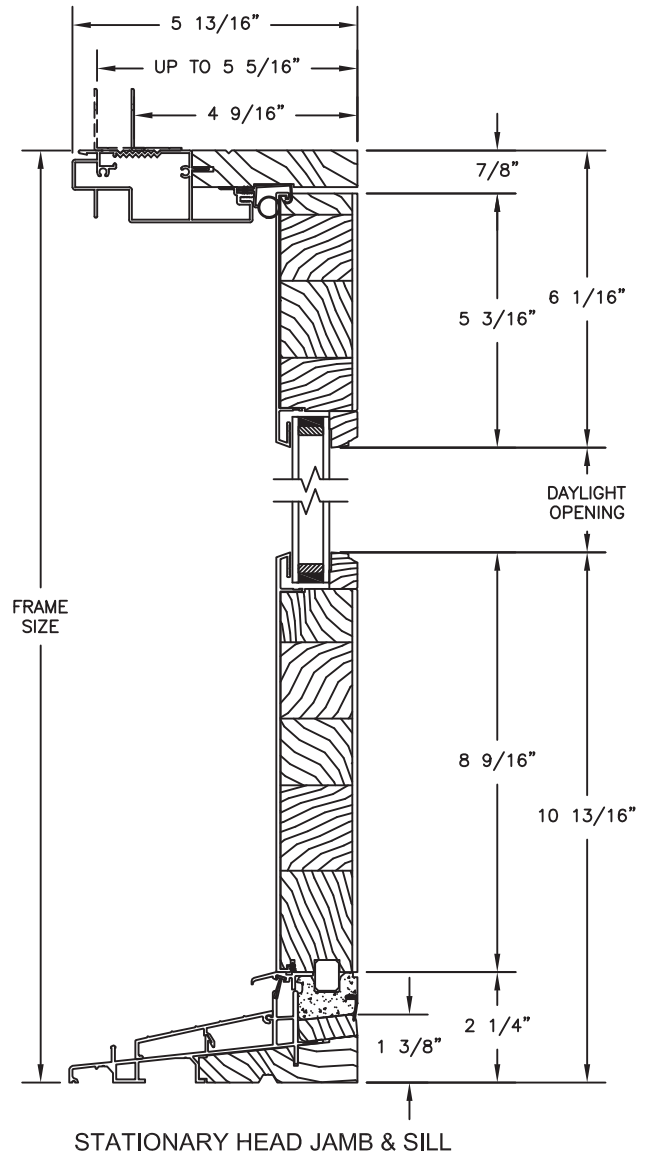
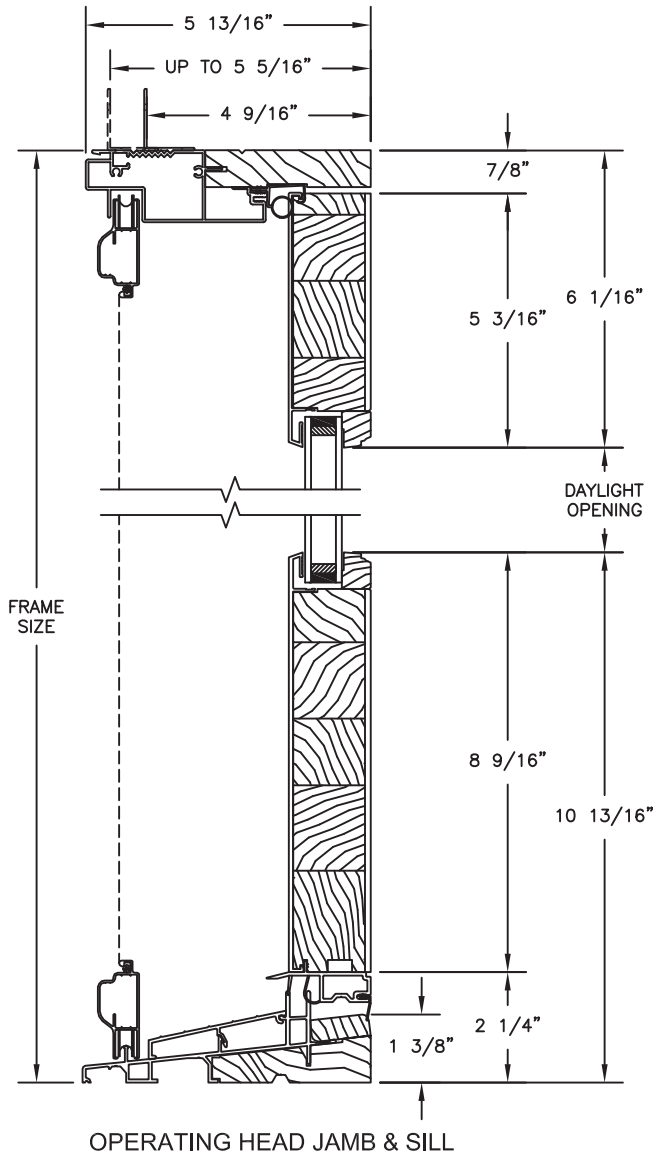

Our products are tested to the standards of and certified by the American Architectural Manufacturer's Association, the National Fenestration Rating Council and the Window & Door Manufacturers Association.



QUAKER
COMMERCIAL WINDOWS AND DOORS



QUAKER
COMMERCIAL WINDOWS AND DOORS



Brighton
R-50
5 15/16" Frame Depth
Hinged Door (Inswing)

BRIGHTON SERIES HINGED DOOR (INSWING)

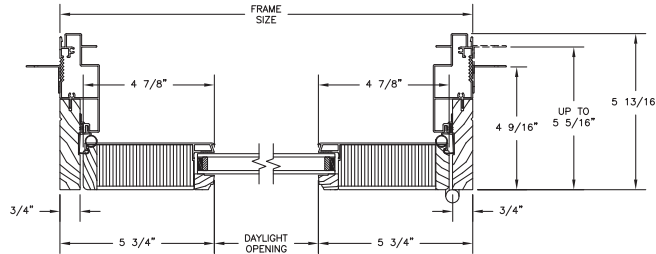

1 PANEL JAMB

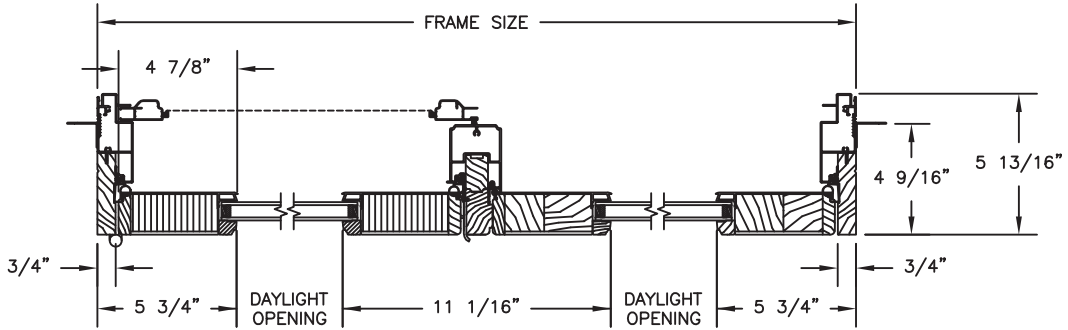

2 PANEL JAMB

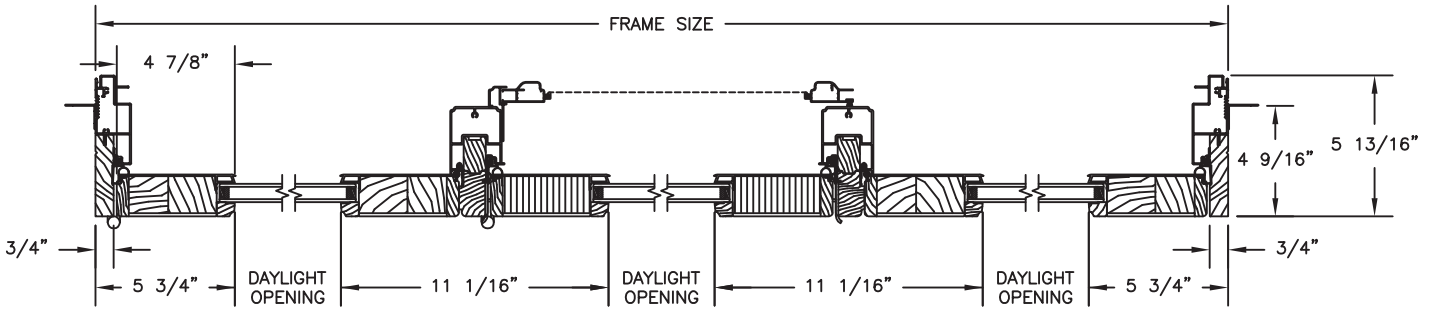

3 PANEL JAMB

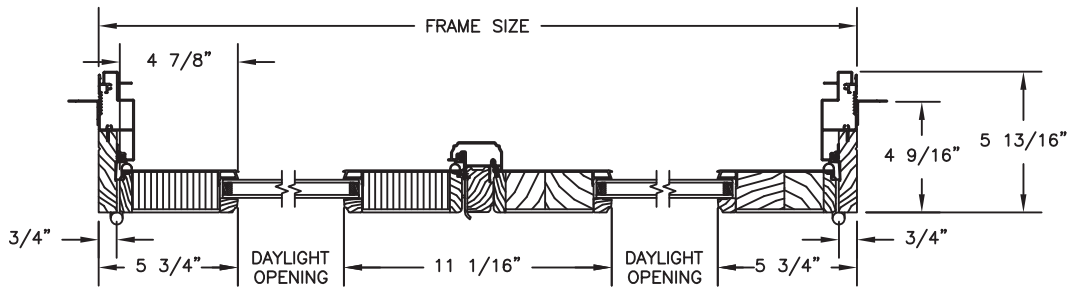

BI-HINGE JAMB

Our products are tested to the standards of and certified by the American Architectural Manufacturer's Association, the National Fenestration Rating Council and the Window & Door Manufacturers Association.



QUAKER
COMMERCIAL WINDOWS AND DOORS